



Board of Directors

Brian Brennan, Director
Richard Hajas, Director
Neil Cole, Director

Mary Bergen, Director
Pete Kaiser, Director

CASITAS MUNICIPAL WATER DISTRICT
Meeting to be held at the

District Office
1055 Ventura Ave.
Oak View, CA 93022

Join Zoom Meeting

<https://us06web.zoom.us/j/98414854813?pwd=UXhtWS9zdm83ZU5CazNXenlEVEIRUT09>
Meeting ID: 984 1485 4813 Passcode: 757052

To join the meeting via telephone please call (888) 788-0099 or (877) 853-5247
Enter Meeting ID: 984 1485 4813# Passcode: 757052

October 26, 2022 @ 5:00 PM

Right to be heard: Members of the public have a right to address the Board directly on any item of interest to the public which is within the subject matter jurisdiction of the Board. The request to be heard should be made immediately before the Board's consideration of the item. No action shall be taken on any item not appearing on the agenda unless the action is otherwise authorized by subdivision (b) of §54954.2 of the Government Code and except that members of a legislative body or its staff may briefly respond to statements made or questions posed by persons exercising their public testimony rights under section 54954.3 of the Government Code.

Special Accommodations: If you require special accommodations for attendance at or participation in this meeting, please notify our office 24 hours in advance at (805) 649-2251, ext. 113. (Govt. Code Section 54954.1 and 54954.2(a)).

1. CALL TO ORDER
2. ROLL CALL
3. PLEDGE OF ALLEGIANCE

4. AGENDA CONFIRMATION
5. PUBLIC COMMENTS - Presentation on District related items that are not on the agenda - three minute limit.
6. CONSENT AGENDA
 - 6.a. Accounts Payable Report.
[Accounts Payable Report.pdf](#)
 - 6.b. Minutes of the October 12, 2022 Board Meeting.
[10 12 2022 Min.pdf](#)
7. ACTION ITEMS
 - 7.a. Discussion and Possible Action on a Draft State Water Project Water Supply Exchange Agreement with the City of Ventura.
[Board Memo Exchange Water Supply Agreement 102622.pdf](#)
[Casitas-Ventura Draft Agreement for Exchange Water Supply Deliveries 102622 ATT1.pdf](#)
 - 7.b. Approval of a revised Casitas MWD Reserve Policy.
[Board Memo for Reserve Policy Revision 102622.pdf](#)
[Reserve Policy Draft 102622 ATT1.pdf](#)
 - 7.c. Setting of Casitas MWD reserve account for Fiscal Year 2022-2023.
[Board Memo for Setting of Reserves 102622.pdf](#)
[Reserves ending Balance FY22 102622 ATT1.pdf](#)
 - 7.d. Declaration of Surplus Casitas MWD Assets.
[Board Memo Surplus Items 102622.pdf](#)
 - 7.e. Approval of an Unbudgeted Item in the amount of \$48,000 and Award a Contract to the Lowest Responsible Bidder, C&W Diving, in the Amount not-to-exceed \$34,000.92 to perform Casitas Dam Intake Structure anodes replacement.
[Board Memo for Casitas Dam Intake Structure Anodes Replacement 102622.pdf](#)
[Anode Cut Sheet ATT1.pdf](#)
[JFB Anode Proposal 102622 ATT2.pdf](#)
[C&W Anode Proposal 102622 ATT3.pdf](#)
 - 7.f. Approve a budget of \$60,000 for the Camp Chaffee Pump Station and authorize the General Manager to issue a Task Order to Cannon Corporation for Camp Chaffee Pump Station design services in an amount not to exceed \$39,250.00.
[Camp Chaffee PS_Board Memo_10262022.pdf](#)
[Camp Chaffee Foster Park Proposal 10.13.22.pdf](#)
 - 7.g. Cancellation of the November 23, 2022 and December 28, 2022 Casitas MWD Board Meetings.

8. INFORMATION ITEMS

- 8.a. Hydrology Report.
[Hydrology September 2022.pdf](#)
- 8.b. Recreation Committee Minutes.
[Rec Minutes 101122.pdf](#)
- 8.c. Letter from Ventura River Water District regarding Casitas MWD's Stage 4 Implementation.
[Letter from Ventura River Water District regarding Stage 4 102622.pdf](#)

9. GENERAL MANAGER COMMENTS

10. BOARD OF DIRECTOR REPORTS ON MEETINGS ATTENDED

11. BOARD OF DIRECTOR COMMENTS PER GOVERNMENT CODE SECTION 54954.2(a).

12. CLOSED SESSION

- 12.a. CONFERENCE WITH LEGAL COUNSEL – EXISTING LITIGATION (Government Code Section 54956.9(a) Santa Barbara Channelkeeper v. State Water Resources Control Board, City of San Buenaventura, et al.; and City of San Buenaventura v Duncan Abbott, et al., Cross Complaint; Superior Court of the State of California, County of Los Angeles, Case No. 19STCP01176.

13. ADJOURNMENT

CASITAS MUNICIPAL WATER DISTRICT
General Fund Check Authorization
Checks Dated 10/07/22 - 10/19/22
Presented to the Board of Directors For Approval October 26, 2022

| Check | Payee | | Description | Amount |
|--------------|-----------------------|--------------|-------------------------------|------------------------|
| 001155 | Payables Fund Account | # 9759651478 | Accounts Payable Batch 101222 | \$ 332,339.49 |
| 001157 | Payables Fund Account | # 9759651478 | Accounts Payable Batch 101922 | \$ 559,041.26 |
| | | | | <u>\$ 891,380.75</u> |
| 001156 | Payroll Found Account | # 9469730919 | Estimated Payroll 11/03/22 | \$ 260,000.00 |
| | | | Total | <u>\$ 1,151,380.75</u> |

Publication of check register is in compliance with Section 53065.6 of the Government Code which requires the District to disclose reimbursements to employees and/or directors.

The above numbered checks, 001155-001157 have been duly audited is hereby certified as correct.

Janyne Brown, Chief Financial Officer

A/P Fund

Publication of check register is in compliance with Section 53065.6 of the Government Code which requires the District to disclose reimbursements to employees and/or directors.

001155 A/P Checks: 047833-047897
 A/P Draft 000426
 Voids:
 047836 - Amazon Capital Services - Continuation of detail of check #047835
 047870 - J.W. Enterprises - Continuation of detail of check 047869

001157 A/P Checks: 047898-047978
 A/P Draft 00427-00434
 Voids:
 047902 - Amazon Capital Services - Continuation of detail of check #047901
 047925 - Corvel Corporation - Continuation of detail of check #047924
 047926 - Corvel Corporation - Continuation of detail of check #047924
 047950 - Meiners Oaks Ace Hardware - Continuation of detail of Check #047949



Janyne Brown , Chief Financial Officer

CERTIFICATION

Payroll disbursements for the pay period ending 10/15/22

Pay Date 10/20/22

have been duly audited and are
hereby certified as correct.

Signed: 

Janyne Brown

| VENDOR I.D. | NAME | STATUS | CHECK DATE | INVOICE AMOUNT | DISCOUNT | CHECK NO | CHECK STATUS | CHECK AMOUNT |
|-------------|------------|--------|------------|----------------|----------|----------|--------------|--------------|
| C-CHECK | VOID CHECK | V | 10/12/2022 | | | 047836 | | |
| C-CHECK | VOID CHECK | V | 10/12/2022 | | | 047870 | | |
| C-CHECK | VOID CHECK | V | 10/19/2022 | | | 047902 | | |
| C-CHECK | VOID CHECK | V | 10/19/2022 | | | 047925 | | |
| C-CHECK | VOID CHECK | V | 10/19/2022 | | | 047926 | | |
| C-CHECK | VOID CHECK | V | 10/19/2022 | | | 047950 | | |

| * * T O T A L S * * | NO | INVOICE AMOUNT | DISCOUNTS | CHECK AMOUNT |
|---------------------|----|-------------------|-----------|--------------|
| REGULAR CHECKS: | 0 | 0.00 | 0.00 | 0.00 |
| HAND CHECKS: | 0 | 0.00 | 0.00 | 0.00 |
| DRAFTS: | 0 | 0.00 | 0.00 | 0.00 |
| EFT: | 0 | 0.00 | 0.00 | 0.00 |
| NON CHECKS: | 0 | 0.00 | 0.00 | 0.00 |
| VOID CHECKS: | 6 | VOID DEBITS 0.00 | | |
| | | VOID CREDITS 0.00 | 0.00 | 0.00 |
| TOTAL ERRORS: | 0 | | | |

| VENDOR SET: 01 BANK: | TOTALS: | NO | INVOICE AMOUNT | DISCOUNTS | CHECK AMOUNT |
|----------------------|---------|----|----------------|-----------|--------------|
| BANK: | TOTALS: | 6 | 0.00 | 0.00 | 0.00 |
| | | 6 | 0.00 | 0.00 | 0.00 |

| VENDOR I.D. | NAME | STATUS | CHECK DATE | INVOICE AMOUNT | DISCOUNT | CHECK NO | CHECK STATUS | CHECK AMOUNT |
|-------------|--|--------|------------|----------------|----------|----------|--------------|--------------|
| 05939 | Health Equity I-INV4295492 Reimburse Med/Dep Care | D | 10/12/2022 | 25.00 | | 000426 | | 25.00 |
| 05939 | Health Equity I-INV4314663 Reimburse Med/Dep Care | D | 10/19/2022 | 558.07 | | 000427 | | 558.07 |
| 00131 | JCI JONES CHEMICALS, INC I-897879 Chlorine - TP, CM 897894 | D | 10/19/2022 | 5,075.64 | | 000428 | | 5,075.64 |
| 00128 | INTERNAL REVENUE SERVICE I-T1 202210172136 Federal Withholding | D | 10/19/2022 | 44,717.67 | | 000429 | | |
| | I-T3 202210172136 SS Withholding | D | 10/19/2022 | 39,203.80 | | 000429 | | |
| | I-T4 202210172136 Medicare Withholding | D | 10/19/2022 | 10,624.41 | | 000429 | | 94,545.88 |
| 00187 | CALPERS I-PBB202210172136 PERS BUY BACK | D | 10/19/2022 | 130.46 | | 000430 | | |
| | I-PBP202210172136 PERS BUY BACK | D | 10/19/2022 | 161.96 | | 000430 | | |
| | I-PEB202210172136 PEPRA EMPLOYEES PORTION | D | 10/19/2022 | 9,880.37 | | 000430 | | |
| | I-PEM202210172136 PERS EMPLOYEE PORTION MGMT | D | 10/19/2022 | 1,882.42 | | 000430 | | |
| | I-PER202210172136 PERS EMPLOYEE PORTION | D | 10/19/2022 | 7,842.44 | | 000430 | | |
| | I-PRB202210172136 PEBRA EMPLOYER PORTION | D | 10/19/2022 | 10,934.27 | | 000430 | | |
| | I-PRR202210172136 PERS EMPLOYER PORTION | D | 10/19/2022 | 12,837.00 | | 000430 | | 43,668.92 |
| 00180 | S.E.I.U. - LOCAL 721 I-COP202210172136 SEIU 721 COPE | D | 10/19/2022 | 2.50 | | 000431 | | |
| | I-UND202210172136 UNION DUES | D | 10/19/2022 | 922.75 | | 000431 | | 925.25 |
| 00049 | STATE OF CALIFORNIA I-T2 202210172136 STATE WITHHOLDING (CA) | D | 10/19/2022 | 17,481.73 | | 000432 | | 17,481.73 |
| 05790 | STATE OF OREGON I-OST202210172136 OR STATE TRANSIT TAX | D | 10/19/2022 | 5.91 | | 000433 | | |
| | I-T2 202210172136 STATE WITHHOLDING (OR) | D | 10/19/2022 | 439.35 | | 000433 | | 445.26 |
| 01483 | CORVEL CORPORATION I-101822-CMWD Corvel Claims - 10/02-10/18/22 | D | 10/19/2022 | 4,439.03 | | 000434 | | 4,439.03 |
| 00010 | AIRGAS USA LLC I-9130305637 Tools for Truck - PL | R | 10/12/2022 | 984.52 | | 047833 | | |
| | I-9130352533 Welding Supplies - PL | R | 10/12/2022 | 1,343.14 | | 047833 | | 2,327.66 |
| 00012 | ALL-PHASE ELECTRIC SUPPLY CO. I-5665-1028027 600V SPCL Purp Fuse - EM | R | 10/12/2022 | 134.28 | | 047834 | | 134.28 |

| VENDOR I.D. | NAME | STATUS | CHECK DATE | INVOICE AMOUNT | DISCOUNT | CHECK NO | CHECK STATUS | CHECK AMOUNT |
|------------------|--------------------------------|--------|------------|----------------|----------|----------|--------------|--------------|
| 03044 | Amazon Capital Services | | | | | | | |
| C-1V7V-NMDK-7M16 | Work Jumpsuite Return - LCRA | R | 10/12/2022 | 81.48CR | | 047835 | | |
| I-116C-MC1D-VRN1 | Bug Guard - UT | R | 10/12/2022 | 96.45 | | 047835 | | |
| I-13RM-C43V-9FFX | Keyboard - LAB | R | 10/12/2022 | 36.09 | | 047835 | | |
| I-1637-J1FJ-VQRN | Office Supplies - PR | R | 10/12/2022 | 52.33 | | 047835 | | |
| I-1637-J1FJ-VRCN | Hard Hat - PR | R | 10/12/2022 | 17.69 | | 047835 | | |
| I-1F71-X4KW-94Y1 | Work Jumpsuit - LCRA | R | 10/12/2022 | 81.48 | | 047835 | | |
| I-1J64-J7RV-PFK1 | Ratchet Strap Tie Down - MAINT | R | 10/12/2022 | 78.28 | | 047835 | | |
| I-1J64-J7RV-T116 | Engine Spark Plug - MAINT | R | 10/12/2022 | 56.08 | | 047835 | | |
| I-1MT3-J1M7-KGFG | Ratchet Straps - MAINT | R | 10/12/2022 | 77.20 | | 047835 | | |
| I-1MY4-X3PC-VXCQ | Tool Box - TP | R | 10/12/2022 | 458.13 | | 047835 | | |
| I-1NNR-MQ31-NXFJ | Ratchet Strap Tie Down - MAINT | R | 10/12/2022 | 78.28 | | 047835 | | |
| I-1NVJ-KHDV-M4VF | Wax for Cars - PL | R | 10/12/2022 | 102.82 | | 047835 | | |
| I-1X1L-X4JN-G7TK | Ram for Newer TP Dell - EM | R | 10/12/2022 | 729.10 | | 047835 | | |
| I-1XWD-CNQL-TCW9 | Violation Stickers Notice - MA | R | 10/12/2022 | 18.18 | | 047835 | | 1,800.63 |
| 00029 | AMERICAN TOWER CORP | | | | | | | |
| I-4027245 | Tower Rent - Red Mountain | R | 10/12/2022 | 1,087.40 | | 047837 | | 1,087.40 |
| 00014 | AQUA-FLO SUPPLY | | | | | | | |
| I-SI1999717 | 4" UL Electrical Sch - LCRA | R | 10/12/2022 | 3,453.35 | | 047838 | | |
| I-SI1999750 | Fittings - PL | R | 10/12/2022 | 32.39 | | 047838 | | |
| I-SI2003032 | Adapter & PVC Cement - EM | R | 10/12/2022 | 30.67 | | 047838 | | |
| I-SI2003552 | Adapter, PVC Pipe & Brass Bush | R | 10/12/2022 | 16.41 | | 047838 | | |
| I-SI2003554 | Hat - PL | R | 10/12/2022 | 21.33 | | 047838 | | 3,554.15 |
| 01323 | ARGO CHEMICAL INC | | | | | | | |
| I-2209213 | Ammonia Solution - TP | R | 10/12/2022 | 6,146.53 | | 047839 | | 6,146.53 |
| 01666 | AT & T | | | | | | | |
| I-000018901152 | Local, Regional, Long Distance | R | 10/12/2022 | 1,295.25 | | 047840 | | 1,295.25 |
| 03429 | AT&T | | | | | | | |
| I-3142711775 | Acct#80030939773 | R | 10/12/2022 | 12.70 | | 047841 | | 12.70 |
| 04254 | Automation Services, LLC | | | | | | | |
| I-22-076 | SCADA Reporting System Upgrade | R | 10/12/2022 | 5,883.33 | | 047842 | | |
| I-22-077 | Programming Robles Dam - ENG | R | 10/12/2022 | 1,197.76 | | 047842 | | |
| I-22-078 | Programming Service - ENG | R | 10/12/2022 | 822.32 | | 047842 | | 7,903.41 |
| 00021 | AWA OF VENTURA COUNTY | | | | | | | |
| I-06-14382 | CCWUC Education Training - LAB | R | 10/12/2022 | 30.00 | | 047843 | | 30.00 |

| VENDOR I.D. | NAME | STATUS | CHECK DATE | INVOICE AMOUNT | DISCOUNT | CHECK NO | CHECK STATUS | CHECK AMOUNT |
|----------------|-------------------------------|--------|------------|----------------|----------|----------|--------------|--------------|
| 00030 | B&R TOOL AND SUPPLY CO | | | | | | | |
| I-1900978723 | Marking Paint - ENG | R | 10/12/2022 | 348.72 | | 047844 | | |
| I-1900978880 | Skid Steer - Unit 104 | R | 10/12/2022 | 485.77 | | 047844 | | |
| I-1900978980 | Gray Bumper - ENG | R | 10/12/2022 | 327.39 | | 047844 | | 1,161.88 |
| 00679 | BAKERSFIELD PIPE & SUPPLY INC | | | | | | | |
| I-S2963224.002 | Gaskets - EM | R | 10/12/2022 | 43.10 | | 047845 | | 43.10 |
| 00756 | BOARD OF EQUALIZATION | | | | | | | |
| I-093022 | Use Tax Return 15300115 | R | 10/12/2022 | 602.00 | | 047846 | | 602.00 |
| 03702 | Cannon Corporation | | | | | | | |
| I-81921 | WP Structure Survey - WP | R | 10/12/2022 | 157.00 | | 047847 | | 157.00 |
| 09907 | CARUS PHOSPHATES, INC. | | | | | | | |
| I-SLS10103598 | Blended Phosphate - TP | R | 10/12/2022 | 34,764.84 | | 047848 | | 34,764.84 |
| 00055 | CASITAS BOAT RENTALS | | | | | | | |
| I-Sep 22 | Gas for Boats - LCRA | R | 10/12/2022 | 249.53 | | 047849 | | 249.53 |
| 00511 | Centers for Family Health | | | | | | | |
| I-109220 | DOT Physical - UT | R | 10/12/2022 | 120.00 | | 047850 | | 120.00 |
| 00061 | COMPUWAVE | | | | | | | |
| I-SB02099899 | Cisco Smartnet - IT | R | 10/12/2022 | 120.00 | | 047851 | | 120.00 |
| 00062 | CONSOLIDATED ELECTRICAL | | | | | | | |
| I-9009-1026524 | 32PT AC IN/RELY MO - EM | R | 10/12/2022 | 5,319.00 | | 047852 | | 5,319.00 |
| 00770 | CORRPRO COMPANIES, INC. | | | | | | | |
| I-701573 | Reservoir Cathodic Protection | R | 10/12/2022 | 9,450.00 | | 047853 | | 9,450.00 |
| 03652 | Cummins Inc. | | | | | | | |
| I-X3-44290 | Repair to standby Generator | R | 10/12/2022 | 783.60 | | 047854 | | 783.60 |
| 02041 | Custom Mailing Solutions, Inc | | | | | | | |
| I-71963 | 2022 Fall Newsletter Mailing | R | 10/12/2022 | 6,701.27 | | 047855 | | 6,701.27 |
| 01001 | CUSTOM PRINTING | | | | | | | |
| I-164335 | 2022 Fall Newsletter - PR | R | 10/12/2022 | 4,404.25 | | 047856 | | 4,404.25 |
| 06008 | Docu Products | | | | | | | |
| I-247358 | Copier Usage - DO | R | 10/12/2022 | 168.91 | | 047857 | | |
| I-247743 | Copier Usage - DO | R | 10/12/2022 | 168.91 | | 047857 | | 337.82 |

| VENDOR I.D. | NAME | STATUS | CHECK DATE | INVOICE AMOUNT | DISCOUNT | CHECK NO | CHECK STATUS | CHECK AMOUNT |
|------------------|--------------------------------|--------|------------|----------------|----------|----------|--------------|--------------|
| 03910 | DoiT International USA, INC | | | | | | | |
| I-IN224005942 | Google Apps 09/22 | R | 10/12/2022 | 2,554.50 | | 047858 | | 2,554.50 |
| 00086 | E.J. Harrison & Sons Inc | | | | | | | |
| I-632 | Acct#1C00054230 | R | 10/12/2022 | 6,306.32 | | 047859 | | 6,306.32 |
| 05937 | Enterprise FM Trust | | | | | | | |
| I-FBN4568140 | Vehicle Maintenance | R | 10/12/2022 | 62,323.92 | | 047860 | | 62,323.92 |
| 00091 | ERNST & YOUNG LLP | | | | | | | |
| I-US01U001061191 | Client#0012205436 | R | 10/12/2022 | 1,362.00 | | 047861 | | 1,362.00 |
| 00713 | FLUID MANUFACTURING | | | | | | | |
| I-48732 | Tokens - LCRA | R | 10/12/2022 | 1,974.63 | | 047862 | | 1,974.63 |
| 00115 | GRAINGER, INC | | | | | | | |
| I-9471412297 | Pipe Freezing Tool - UT | R | 10/12/2022 | 5,003.35 | | 047863 | | |
| I-9471412313 | Axial Confined Space Fan - UT | R | 10/12/2022 | 428.48 | | 047863 | | 5,431.83 |
| 03856 | Granicus, LLC | | | | | | | |
| I-157246 | Maint, Hosting & Licensing Fee | R | 10/12/2022 | 8,596.19 | | 047864 | | 8,596.19 |
| 02217 | Greg Rents | | | | | | | |
| I-41515 | Fill Sand/Gravel - PL | R | 10/12/2022 | 197.07 | | 047865 | | |
| I-41516 | Spy Glasses - PL | R | 10/12/2022 | 80.44 | | 047865 | | |
| I-41633 | Vibe Plate Rental - LCRA | R | 10/12/2022 | 118.14 | | 047865 | | 395.65 |
| 05708 | Daniel J Holloway | | | | | | | |
| I-Oct 22 | Reimburse Expenses 10/22 | R | 10/12/2022 | 115.81 | | 047866 | | 115.81 |
| 00596 | HOME DEPOT | | | | | | | |
| I-495681 | Air Vacuum Pump - PL | R | 10/12/2022 | 174.28 | | 047867 | | |
| I-5902880 | Yard Waste Card - TP | R | 10/12/2022 | 130.31 | | 047867 | | |
| I-6285523 | Mini Blind - MAINT | R | 10/12/2022 | 282.09 | | 047867 | | |
| I-876240 | Cover for Ductless Mini Split | R | 10/12/2022 | 301.09 | | 047867 | | 887.77 |
| 00125 | IDEXX DISTRIBUTION CORP | | | | | | | |
| I-3115229969 | Coli 1 & Bacti Bottles - LAB | R | 10/12/2022 | 1,205.65 | | 047868 | | 1,205.65 |
| 09910 | J.W. ENTERPRISES | | | | | | | |
| I-31009 | CT Pumping - CASITAS DAM | R | 10/12/2022 | 80.75 | | 047869 | | |
| I-356595 | CT Pumping - VILLANOVA | R | 10/12/2022 | 80.75 | | 047869 | | |
| I-356596 | CT Pumping - OVPP | R | 10/12/2022 | 80.75 | | 047869 | | |
| I-356597 | CT Pumping - 4M PP | R | 10/12/2022 | 80.75 | | 047869 | | |
| I-356598 | CT Pumping - GRAND AVE. | R | 10/12/2022 | 80.75 | | 047869 | | |
| I-356599 | CT Pumping - 4M RES. | R | 10/12/2022 | 80.75 | | 047869 | | |
| I-356600 | CT Pumping - SA PLANT | R | 10/12/2022 | 161.50 | | 047869 | | |
| I-356601 | CT Pumping - UPPER OJAI RES. | R | 10/12/2022 | 80.75 | | 047869 | | |

| VENDOR I.D. | NAME | STATUS | CHECK DATE | INVOICE AMOUNT | DISCOUNT | CHECK NO | CHECK STATUS | CHECK AMOUNT |
|----------------|--------------------------------|--------|------------|----------------|----------|----------|--------------|--------------|
| I-356602 | CT Pumping - 3M PUMP | R | 10/12/2022 | 80.75 | | 047869 | | |
| I-356603 | CT Pumping - SIGNAL RES. | R | 10/12/2022 | 80.75 | | 047869 | | |
| I-356604 | CT Pumping - FAIRVIEW RES. | R | 10/12/2022 | 80.75 | | 047869 | | |
| I-356606 | CT Pumping - RINCON TANK | R | 10/12/2022 | 80.75 | | 047869 | | |
| I-356607 | CT Pumping - BATES RES. | R | 10/12/2022 | 80.75 | | 047869 | | 1,130.50 |
| 00667 | Kennedy/Jenks Consultants, Inc | | | | | | | |
| I-158211 | On-Call Wellfield Tech - ENG | R | 10/12/2022 | 1,661.25 | | 047871 | | 1,661.25 |
| 00151 | MEINERS OAKS ACE HARDWARE | | | | | | | |
| I-019361 | Adj Wrench & Shut-Off - UT | R | 10/12/2022 | 101.75 | | 047872 | | |
| I-020186 | Netting Wire & Plant Supports | R | 10/12/2022 | 44.80 | | 047872 | | |
| I-020191 | Nozzle Gun - LCRA | R | 10/12/2022 | 10.92 | | 047872 | | |
| I-020272 | Fast Set Accelerator - ENG | R | 10/12/2022 | 51.35 | | 047872 | | |
| I-020279 | Blades - EM | R | 10/12/2022 | 29.23 | | 047872 | | |
| I-020284 | Packing Sheet - LCRA | R | 10/12/2022 | 14.61 | | 047872 | | |
| I-020297 | Couplings - LCRA | R | 10/12/2022 | 17.56 | | 047872 | | |
| I-020306 | Painting Supplies - MAINT | R | 10/12/2022 | 14.82 | | 047872 | | |
| I-020354 | Torx Bit - MAINT | R | 10/12/2022 | 7.48 | | 047872 | | |
| I-020369 | Paint - LCRA | R | 10/12/2022 | 39.73 | | 047872 | | 332.25 |
| 03724 | Michael K. Nunley & Associates | | | | | | | |
| I-101338 | Mutual Well#7 Equipment - ENG | R | 10/12/2022 | 1,670.63 | | 047873 | | |
| I-101371 | Ojai Valley PP - ENG | R | 10/12/2022 | 10,112.89 | | 047873 | | 11,783.52 |
| 03444 | Mission Linen Supply | | | | | | | |
| I-517914173 | Uniform Pants - PL | R | 10/12/2022 | 32.36 | | 047874 | | |
| I-517914174 | Uniform Pants - MAINT | R | 10/12/2022 | 28.27 | | 047874 | | |
| I-517914178 | Uniform Pants - TP | R | 10/12/2022 | 52.09 | | 047874 | | 112.72 |
| 03969 | NEOGOV | | | | | | | |
| I-INV-27110 | NEOGOV Subscription 22/23 | R | 10/12/2022 | 6,402.39 | | 047875 | | 6,402.39 |
| 05994 | NV5, Inc | | | | | | | |
| I-000000290315 | WP Structure Design - WP | R | 10/12/2022 | 15,900.00 | | 047876 | | 15,900.00 |
| 05977 | ODP Business Solutions, LLC | | | | | | | |
| I-267712029001 | Gregg Rule - ADM | R | 10/12/2022 | 9.88 | | 047877 | | |
| I-267714108001 | Office Supplies - ADM | R | 10/12/2022 | 87.99 | | 047877 | | |
| I-267714118001 | Envelopes - ADM | R | 10/12/2022 | 107.11 | | 047877 | | |
| I-269993204001 | Office Supplies - ADM | R | 10/12/2022 | 318.93 | | 047877 | | 523.91 |
| 01570 | Ojai Auto Supply | | | | | | | |
| I-10.01 | Lamp - Unit 41 | R | 10/12/2022 | 10.01 | | 047878 | | 10.01 |

| VENDOR I.D. | NAME | STATUS | CHECK DATE | INVOICE AMOUNT | DISCOUNT | CHECK NO | CHECK STATUS | CHECK AMOUNT |
|------------------|--------------------------------|--------|------------|----------------|----------|----------|--------------|--------------|
| 01882 | OJAI BASIN GROUNDWATER | | | | | | | |
| I-093022 | Quarterly Pumping Fee | R | 10/12/2022 | 24,581.40 | | 047879 | | 24,581.40 |
| 00165 | OJAI LUMBER CO, INC | | | | | | | |
| I-2209-706263 | Select Rwd - LCRA | R | 10/12/2022 | 269.80 | | 047880 | | |
| I-2210-706531 | 2X12 Boards - EM | R | 10/12/2022 | 267.48 | | 047880 | | |
| I-2210-707210 | Plywood - PL | R | 10/12/2022 | 58.68 | | 047880 | | 595.96 |
| 00169 | OJAI VALLEY SANITARY DISTRICT | | | | | | | |
| I-24485 | Cust #20594 | R | 10/12/2022 | 302.25 | | 047881 | | 302.25 |
| 00169 | OJAI VALLEY SANITARY DISTRICT | | | | | | | |
| I-24563 | Cust #52921 | R | 10/12/2022 | 60.45 | | 047882 | | 60.45 |
| 05713 | Pops Auto Repair | | | | | | | |
| I-0301 | Tint Windows -Unit E07 | R | 10/12/2022 | 400.00 | | 047883 | | |
| I-0302 | Pressure Pump Wash - GARAGE | R | 10/12/2022 | 400.00 | | 047883 | | |
| I-0303 | Delivered Totes - LAB | R | 10/12/2022 | 700.00 | | 047883 | | 1,500.00 |
| 00790 | PROFORMA | | | | | | | |
| I-BI85008067A | Uniform Shirts - LAB | R | 10/12/2022 | 370.34 | | 047884 | | 370.34 |
| 10042 | PSR ENVIRONMENTAL SERVICE, INC | | | | | | | |
| I-11017 | Gas Tank Inspection - DO | R | 10/12/2022 | 230.00 | | 047885 | | |
| I-11018 | Gas Tank Inspection - LCRA | R | 10/12/2022 | 230.00 | | 047885 | | 460.00 |
| 00788 | QUINN COMPANY | | | | | | | |
| C-PR010051977 | Deposit Return - EM | R | 10/12/2022 | 43.70CR | | 047886 | | |
| I-WO110106609 | Seat Belt & Lights - Unit 287 | R | 10/12/2022 | 579.91 | | 047886 | | 536.21 |
| 00732 | QUINN RENTAL SERVICES | | | | | | | |
| I-PC010423246 | SA Generator Battery - EM | R | 10/12/2022 | 591.11 | | 047887 | | 591.11 |
| 01109 | SALVADOR LOERA TRANSPORTATION | | | | | | | |
| I-188428 | Base for Dam Road - MAINT | R | 10/12/2022 | 800.00 | | 047888 | | 800.00 |
| 00215 | SOUTHERN CALIFORNIA EDISON | | | | | | | |
| I-100722a | Acct#700028735181 | R | 10/12/2022 | 18,901.00 | | 047889 | | |
| I-100722b | Acct#700598317666 | R | 10/12/2022 | 35.19 | | 047889 | | |
| I-100722c | Acct#700030209177 | R | 10/12/2022 | 18,886.60 | | 047889 | | 37,822.79 |
| 02703 | Sunbelt Rentals | | | | | | | |
| I-130700737-0002 | Emergency Generator Rental -EM | R | 10/12/2022 | 19,614.36 | | 047890 | | 19,614.36 |

| VENDOR I.D. | NAME | STATUS | CHECK DATE | INVOICE AMOUNT | DISCOUNT | CHECK NO | CHECK STATUS | CHECK AMOUNT |
|------------------|--------------------------------|--------|------------|----------------|----------|----------|--------------|--------------|
| 01696 | SUPERIOR MACHINE | | | | | | | |
| I-4973 | Machine Work - EM | R | 10/12/2022 | 409.45 | | 047891 | | 409.45 |
| 01959 | The Wharf | | | | | | | |
| I-401738 | Uniform Pants - MAINT | R | 10/12/2022 | 580.40 | | 047892 | | |
| I-404271 | Safety Boots - PR | R | 10/12/2022 | 100.00 | | 047892 | | 680.40 |
| 02163 | Toro Enterprises, Inc. | | | | | | | |
| I-RET11656 | Santa Ana Bridge PL Relo - ENG | R | 10/12/2022 | 21,246.25 | | 047893 | | 21,246.25 |
| 00254 | VENTURA LOCKSMITHS | | | | | | | |
| I-BM0906224 | Duplicate Key - WP | R | 10/12/2022 | 21.55 | | 047894 | | 21.55 |
| 00258 | VENTURA STEEL, INC | | | | | | | |
| I-275628 | Fab 2 Rolled Rings - EM | R | 10/12/2022 | 234.88 | | 047895 | | 234.88 |
| 00247 | County of Ventura | | | | | | | |
| I-342255 | Encroachment Permit PE22-0187- | R | 10/12/2022 | 180.00 | | 047896 | | |
| I-343206 | Encroachment Permit PE22-1077 | R | 10/12/2022 | 390.00 | | 047896 | | |
| I-343374 | Encroachment Permit PE21-0832- | R | 10/12/2022 | 180.00 | | 047896 | | 750.00 |
| 01283 | Verizon Wireless | | | | | | | |
| I-9917335124 | Monthly Cell Charges - DO | R | 10/12/2022 | 3,789.44 | | 047897 | | |
| I-9917335547 | Monthly Cell Charges - LCRA | R | 10/12/2022 | 430.53 | | 047897 | | 4,219.97 |
| 01325 | Aflac Worldwide Headquarters | | | | | | | |
| I-203180 | Supplemental Insurance 10/22 | R | 10/19/2022 | 3,181.84 | | 047898 | | 3,181.84 |
| 00010 | AIRGAS USA LLC | | | | | | | |
| I-9130603583 | Welding Supplies - PL | R | 10/19/2022 | 326.64 | | 047899 | | |
| I-9130603584 | Welding Supplies - PL | R | 10/19/2022 | 62.86 | | 047899 | | |
| I-9130843944 | Hose Coupler - PL | R | 10/19/2022 | 4.43 | | 047899 | | |
| I-9991977804 | Gas Cylinder Rental - PL | R | 10/19/2022 | 409.75 | | 047899 | | 803.68 |
| 00012 | ALL-PHASE ELECTRIC SUPPLY CO. | | | | | | | |
| I-5665-1028348 | EMT Conduit & Clamp - SAFE | R | 10/19/2022 | 384.92 | | 047900 | | |
| I-5665-1028374 | Fittings - PL | R | 10/19/2022 | 48.66 | | 047900 | | 433.58 |
| 03044 | Amazon Capital Services | | | | | | | |
| I-131V-7GQ1-443N | Air Fryers - HR | R | 10/19/2022 | 149.87 | | 047901 | | |
| I-14CC-KDHC-CWGN | Aluminum Square Tubing - MAINT | R | 10/19/2022 | 43.81 | | 047901 | | |
| I-14PF-GRYH-PFNF | Pencils - PR | R | 10/19/2022 | 13.05 | | 047901 | | |
| I-1DYG-4QWY-1TWF | Ratchet Kit - ADM | R | 10/19/2022 | 134.28 | | 047901 | | |
| I-1GRH-LGNM-3TJK | Microsoft Windows 10 Pro - TP | R | 10/19/2022 | 639.44 | | 047901 | | |
| I-1HM7-Q9J9-MT1H | Washer Hose Reel - GARAGE | R | 10/19/2022 | 396.76 | | 047901 | | |
| I-1K1H-73CR-DXPM | Retractable Truck Steps - UT | R | 10/19/2022 | 622.06 | | 047901 | | |
| I-1L6J-JQCG-JWN7 | Retractable Truck Steps - UT | R | 10/19/2022 | 622.06 | | 047901 | | |
| I-1Q9X-LNR7-WVKV | Camera Microphone - PR | R | 10/19/2022 | 38.61 | | 047901 | | |

| VENDOR I.D. | NAME | STATUS | CHECK DATE | INVOICE AMOUNT | DISCOUNT | CHECK NO | CHECK STATUS | CHECK AMOUNT |
|-------------|---------------------|--------|--------------------------------|----------------|------------|----------|--------------|--------------|
| | I-1QPR-6MTC-V39D | | Keyboard - PR | R | 10/19/2022 | 34.31 | | 047901 |
| | I-1RHR-7XP6-GP1K | | Safety Mask - UT | R | 10/19/2022 | 56.09 | | 047901 |
| | I-1THW-G1PC-446N | | Label Tape - IT | R | 10/19/2022 | 16.08 | | 047901 |
| | I-1TJ9-PJWR-C4QP | | Wrapping Paper - MAINT | R | 10/19/2022 | 37.48 | | 047901 |
| | I-1YJ1-H7T6-6XPV | | LED Light Bar - MAINT | R | 10/19/2022 | 54.40 | | 047901 |
| | | | | | | | | 2,858.30 |
| 00014 | | | AQUA-FLO SUPPLY | | | | | |
| | I-SI2003526 | | Copper Tee & Adapter - TP | R | 10/19/2022 | 26.48 | | 047903 |
| | I-SI2004149 | | PVC Cement - LCRA | R | 10/19/2022 | 139.56 | | 047903 |
| | I-SI2005496 | | PVC Coupling - LCRA | R | 10/19/2022 | 30.26 | | 047903 |
| | I-SI2006691 | | Brass Nipple - EM | R | 10/19/2022 | 28.92 | | 047903 |
| | I-SI2007340 | | Electrical - PL | R | 10/19/2022 | 500.35 | | 047903 |
| | | | | | | | | 725.57 |
| 00840 | | | AQUA-METRIC SALES COMPANY | | | | | |
| | I-INV0091134 | | TRPL Cables for Meters - UT | R | 10/19/2022 | 1,358.31 | | 047904 |
| | | | | | | | | 1,358.31 |
| 00018 | | | AT & T MOBILITY | | | | | |
| | I-287290467941X1022 | | Acct#287290467941 | R | 10/19/2022 | 245.16 | | 047905 |
| | I-287294256431X1022 | | Acct#287294256431 | R | 10/19/2022 | 1,087.48 | | 047905 |
| | I-287299383384X1022 | | Acct#287299383384 | R | 10/19/2022 | 77.76 | | 047905 |
| | | | | | | | | 1,410.40 |
| 03429 | | | AT&T | | | | | |
| | I-4356043706 | | Acct#8310011246015 | R | 10/19/2022 | 1,942.25 | | 047906 |
| | | | | | | | | 1,942.25 |
| 05997 | | | Vazgen Avanesian | | | | | |
| | I-1131527 | | Camping Cancellation - LCRA | R | 10/19/2022 | 12.00 | | 047907 |
| | | | | | | | | 12.00 |
| 05140 | | | Annette Ayala | | | | | |
| | I-76 | | Ojai Ave Cultural Monitor -ENG | R | 10/19/2022 | 3,720.00 | | 047908 |
| | | | | | | | | 3,720.00 |
| 00679 | | | BAKERSFIELD PIPE & SUPPLY INC | | | | | |
| | I-S2963616.001 | | 1Lb Jet-Lube Anti-Seize - EM | R | 10/19/2022 | 193.95 | | 047909 |
| | I-S2967137.001 | | Pipeline Parts - PL | R | 10/19/2022 | 633.80 | | 047909 |
| | | | | | | | | 827.75 |
| 05025 | | | Best Buy Business Advantage Ac | | | | | |
| | I-6448604 | | Corsair Memory - PR | R | 10/19/2022 | 109.24 | | 047910 |
| | | | | | | | | 109.24 |
| 00860 | | | Big Red Crane Company, Inc. | | | | | |
| | I-13227 | | Supply Crane for Heidelberg | R | 10/19/2022 | 1,706.60 | | 047911 |
| | | | | | | | | 1,706.60 |
| 03702 | | | Cannon Corporation | | | | | |
| | I-82113 | | Ave 2 PP Upgrades - ENG | R | 10/19/2022 | 222.00 | | 047912 |
| | I-82117 | | Camp Chaffee Design - ENG | R | 10/19/2022 | 358.00 | | 047912 |
| | | | | | | | | 580.00 |

| VENDOR I.D. | NAME | STATUS | CHECK DATE | INVOICE AMOUNT | DISCOUNT | CHECK NO | CHECK STATUS | CHECK AMOUNT |
|------------------|--------------------------------|--------|------------|----------------|----------|----------|--------------|--------------|
| 01234 | CARAHSOFT | | | | | | | |
| I-31645907INV | Linkedin Learning Pro for Gov. | R | 10/19/2022 | 9,500.00 | | 047913 | | 9,500.00 |
| 00208 | CareIQ | | | | | | | |
| I-6/16323677-1 | 1102WC180000001 DOS 06/29/22 | R | 10/19/2022 | 374.12 | | 047914 | | |
| I-6/16336479-1 | 1102WC180000001 DOS 06/24/22 | R | 10/19/2022 | 292.41 | | 047914 | | |
| I-6/16336484-1 | 1102WC180000001 DOS 06/17/22 | R | 10/19/2022 | 326.04 | | 047914 | | |
| I-6/16336486-1 | 1102WC180000001 DOS 06/15/22 | R | 10/19/2022 | 199.19 | | 047914 | | |
| I-6/16337455-1 | 1102WC180000001 DOS 06/24/22 | R | 10/19/2022 | 501.46 | | 047914 | | |
| I-6/16337461-1 | 1102WC180000001 DOS 06/20/22 | R | 10/19/2022 | 326.04 | | 047914 | | |
| I-6/16337482-1 | 1102WC180000001 DOS 06/15/22 | R | 10/19/2022 | 306.76 | | 047914 | | |
| I-6/16338139-1 | 1102WC180000001 DOS 07/06/22 | R | 10/19/2022 | 325.51 | | 047914 | | |
| I-6/16338157-1 | 1102WC180000001 DOS 07/06/22 | R | 10/19/2022 | 325.51 | | 047914 | | |
| I-6/16338168-1 | 1102WC180000001 DOS 06/20/22 | R | 10/19/2022 | 204.58 | | 047914 | | |
| I-6/16379412-1 | 1102WC180000001 DOS 06/21/22 | R | 10/19/2022 | 632.91 | | 047914 | | 3,814.53 |
| 06004 | Catalina Paints | | | | | | | |
| I-00001674 | Base - WP | R | 10/19/2022 | 76.54 | | 047915 | | 76.54 |
| 06010 | Center for Orthopedic Surgery, | | | | | | | |
| I-6/16379773-1 | 1102WC230300001 DOS 08/12/22 | R | 10/19/2022 | 2,920.14 | | 047916 | | 2,920.14 |
| 03021 | Central Communications | | | | | | | |
| I-000026-680-571 | Call Center 09/22 | R | 10/19/2022 | 205.50 | | 047917 | | 205.50 |
| 03978 | Virgil Clary | | | | | | | |
| I-Aug 22 | Reimburse Expense 08/22 | R | 10/19/2022 | 50.31 | | 047918 | | |
| I-Jul 22 | Reimburse Expenses 07/22 | R | 10/19/2022 | 35.81 | | 047918 | | |
| I-Jun 22 | Reimburse Expenses 06/22 | R | 10/19/2022 | 31.94 | | 047918 | | |
| I-May 22 | Reimburse Expenses 05/22 | R | 10/19/2022 | 77.45 | | 047918 | | |
| I-Sep 22 | Reimburse Expenses 09/22 | R | 10/19/2022 | 19.68 | | 047918 | | 215.19 |
| 00058 | COAST TO COAST | | | | | | | |
| I-53349 | Roll of Carpet - UT | R | 10/19/2022 | 216.70 | | 047919 | | 216.70 |
| 00059 | COASTAL PIPCO | | | | | | | |
| I-S2198525.001 | Gallon Can - WP | R | 10/19/2022 | 46.26 | | 047920 | | 46.26 |
| 00061 | COMPUWAVE | | | | | | | |
| I-SB02099959 | CISCO Firepower 1010 ASA - EM | R | 10/19/2022 | 708.53 | | 047921 | | 708.53 |
| 00062 | CONSOLIDATED ELECTRICAL | | | | | | | |
| I-9009-1026567 | Galv Box - EM | R | 10/19/2022 | 113.95 | | 047922 | | 113.95 |

| VENDOR I.D. | NAME | STATUS | CHECK DATE | INVOICE AMOUNT | DISCOUNT | CHECK NO | CHECK STATUS | CHECK AMOUNT |
|----------------|---------------------------------|--------|------------|----------------|----------|----------|--------------|--------------|
| 00719 | CORELOGIC INFORMATION SOLUTION | | | | | | | |
| I-82150506 | Realquest Subscription | R | 10/19/2022 | 137.50 | | 047923 | | 137.50 |
| 01483 | CORVEL CORPORATION | | | | | | | |
| I-6/16304140-1 | 1102WC180000001 DOS 07/06/22 | R | 10/19/2022 | 9.50 | | 047924 | | |
| I-6/16323677-1 | 1102WC180000001 DOS 06/29/22 | R | 10/19/2022 | 9.50 | | 047924 | | |
| I-6/16324597-1 | 1102WC200000006 DOS 07/26/22 | R | 10/19/2022 | 9.50 | | 047924 | | |
| I-6/16324598-1 | 1102WC200000006 DOS 07/27/22 | R | 10/19/2022 | 15.39 | | 047924 | | |
| I-6/16334560-1 | 1102WC200000006 DOS 06/29/22 | R | 10/19/2022 | 12.76 | | 047924 | | |
| I-6/16336479-1 | 1102WC180000001 DOS 06/24/22 | R | 10/19/2022 | 9.50 | | 047924 | | |
| I-6/16336482-1 | 1102WC180000001 DOS 06/17/22 | R | 10/19/2022 | 9.50 | | 047924 | | |
| I-6/16336484-1 | 1102WC180000001 DOS 06/17/22 | R | 10/19/2022 | 9.50 | | 047924 | | |
| I-6/16336486-1 | 1102WC180000001 DOS 06/15/22 | R | 10/19/2022 | 9.50 | | 047924 | | |
| I-6/16337455-1 | 1102WC180000001 DOS 06/24/22 | R | 10/19/2022 | 9.50 | | 047924 | | |
| I-6/16337461-1 | 1102WC180000001 DOS 06/20/22 | R | 10/19/2022 | 9.50 | | 047924 | | |
| I-6/16337482-1 | 1102WC180000001 DOS 06/15/22 | R | 10/19/2022 | 9.50 | | 047924 | | |
| I-6/16338139-1 | 1102WC180000001 DOS 07/06/22 | R | 10/19/2022 | 9.50 | | 047924 | | |
| I-6/16338157-1 | 1102WC180000001 DOS 07/06/22 | R | 10/19/2022 | 9.50 | | 047924 | | |
| I-6/16338168-1 | 1102WC180000001 DOS 06/20/22 | R | 10/19/2022 | 9.50 | | 047924 | | |
| I-6/16347742-1 | 1102WC230300001 DOS 08/01/22 | R | 10/19/2022 | 9.50 | | 047924 | | |
| I-6/16350519-1 | 1102WC230300001 DOS 08/11/22 | R | 10/19/2022 | 39.71 | | 047924 | | |
| I-6/16374996-1 | 1102WC230300001 DOS 08/10/22 | R | 10/19/2022 | 9.50 | | 047924 | | |
| I-6/16379412-1 | 1102WC180000001 DOS 06/21/22 | R | 10/19/2022 | 9.50 | | 047924 | | |
| I-6/16379773-1 | 1102WC230300001 DOS 08/12/22 | R | 10/19/2022 | 1,366.67 | | 047924 | | |
| I-6/16382108-1 | 1102WC230300001 DOS 08/12/22 | R | 10/19/2022 | 170.96 | | 047924 | | |
| I-6/16386306-1 | 1102WC230300001 DOS 08/12/22 | R | 10/19/2022 | 9.50 | | 047924 | | |
| I-6/16389482-1 | 1102WC230300001 DOS 08/12/22 | R | 10/19/2022 | 9.50 | | 047924 | | |
| I-6/16395078-1 | 1102WC230300001 DOS 08/10/22 | R | 10/19/2022 | 9.66 | | 047924 | | |
| I-6/16399061-1 | 1102WC230300001 DOS 08/22/22 | R | 10/19/2022 | 9.50 | | 047924 | | |
| I-6/16414107-1 | 1102WC230300001 DOS 08/22/22 | R | 10/19/2022 | 9.50 | | 047924 | | |
| I-6/16441612-1 | 1102WC230300003 DOS 08/11/22 | R | 10/19/2022 | 9.50 | | 047924 | | |
| I-6/16461886-1 | 1102WC200000006 DOS 08/30/22 | R | 10/19/2022 | 13.97 | | 047924 | | |
| I-C00207051862 | Claim # 1102WC230300001 | R | 10/19/2022 | 1,090.80 | | 047924 | | |
| I-C00207052863 | Calim # 1102WC200000006 | R | 10/19/2022 | 120.00 | | 047924 | | |
| I-C00207058705 | Claim # 1102WC230300001 | R | 10/19/2022 | 120.00 | | 047924 | | |
| I-C00207084372 | Claim #1102WC230300001 | R | 10/19/2022 | 588.00 | | 047924 | | |
| I-C00207084447 | Claim # 1102WC200000006 | R | 10/19/2022 | 120.00 | | 047924 | | 3,867.42 |
| 03756 | County Fire Protection | | | | | | | |
| I-21-28139 | Fire Extinguishers Service-SAF | R | 10/19/2022 | 693.70 | | 047927 | | |
| I-21-28140 | Fire Extinguishers Service-SAF | R | 10/19/2022 | 1,715.76 | | 047927 | | |
| I-21-28141 | Fire Extinguishers Servivce-LCR | R | 10/19/2022 | 1,099.99 | | 047927 | | 3,509.45 |

| VENDOR I.D. | NAME | STATUS | CHECK DATE | INVOICE AMOUNT | DISCOUNT | CHECK NO | CHECK STATUS | CHECK AMOUNT |
|-------------|--|--------|------------|----------------|----------|----------|--------------|--------------|
| 06005 | Custom Contour Construction In Camp Chaffee Concrete Pad -ENG | R | 10/19/2022 | 6,020.00 | | 047928 | | 6,020.00 |
| 06013 | Robert Demoon Camping Cancellation - LCRA | R | 10/19/2022 | 164.00 | | 047929 | | 164.00 |
| 00662 | Diamond A Equipment Key Ignition - PL | R | 10/19/2022 | 92.65 | | 047930 | | 92.65 |
| 00086 | E.J. Harrison & Sons Inc Acct#500139629 | R | 10/19/2022 | 2,034.17 | | 047931 | | 2,034.17 |
| 00086 | E.J. Harrison & Sons Inc Acct#500766090 | R | 10/19/2022 | 101.93 | | 047932 | | 101.93 |
| 00095 | FAMCON PIPE & SUPPLY 4" C900 Pipe & Mega Lug - PL | R | 10/19/2022 | 3,127.41 | | 047933 | | |
| | I-S100089248.001 Washer Rubber Meter - UT | R | 10/19/2022 | 25.74 | | 047933 | | |
| | I-S100089459.001 Pipeline Parts - PL | R | 10/19/2022 | 277.78 | | 047933 | | |
| | I-S100089538.003 Blades - EM | R | 10/19/2022 | 75.08 | | 047933 | | |
| | I-S100089785.001 2" Corp Stop - EM | R | 10/19/2022 | 305.66 | | 047933 | | 3,811.67 |
| 00099 | FGL ENVIRONMENTAL OWS-San Antonio TP-MN 08/09/22 | R | 10/19/2022 | 19.00 | | 047934 | | |
| | I-214668A Lab Water Quality 09/12/22 | R | 10/19/2022 | 58.00 | | 047934 | | |
| | I-214669A Nitrate Monitoring 09/13/22 | R | 10/19/2022 | 57.00 | | 047934 | | |
| | I-215072A Nitrate Monitoring 09/20/22 | R | 10/19/2022 | 57.00 | | 047934 | | |
| | I-215449A Nitrate Monitoring 09/27/22 | R | 10/19/2022 | 57.00 | | 047934 | | 248.00 |
| 05822 | Frank's Underground Utilities, Run Camera - WP | R | 10/19/2022 | 250.00 | | 047935 | | 250.00 |
| 00104 | FRED'S TIRE MAN Tires - Unit 31 | R | 10/19/2022 | 139.67 | | 047936 | | 139.67 |
| 02720 | Garda CL West, Inc. Armored Truck Service | R | 10/19/2022 | 514.54 | | 047937 | | 514.54 |
| 04022 | Hamner, Jewell & Associates Ventura-SB Row Srvs - ENG | R | 10/19/2022 | 4,373.75 | | 047938 | | |
| | I-202060 ROW Service Skyhigh Drive -ENG | R | 10/19/2022 | 31.50 | | 047938 | | 4,405.25 |
| 01052 | HARBOR FREIGHT TOOLS USA, INC Eyeglasses - LCRA | R | 10/19/2022 | 51.64 | | 047939 | | 51.64 |

| VENDOR I.D. | NAME | STATUS | CHECK DATE | INVOICE AMOUNT | DISCOUNT | CHECK NO | CHECK STATUS | CHECK AMOUNT |
|-------------------|--------------------------------|--------|------------|----------------|----------|----------|--------------|--------------|
| 05746 | Hasa Inc. | | | | | | | |
| I-853683 | Chlorine for Ojai Sys. - TP | R | 10/19/2022 | 4,316.03 | | 047940 | | |
| I-854993 | Chlorine for Ojai Sys. - TP | R | 10/19/2022 | 1,256.72 | | 047940 | | 5,572.75 |
| 00596 | HOME DEPOT | | | | | | | |
| I-3373475 | Truck 52 Vaccum - EM | R | 10/19/2022 | 234.76 | | 047941 | | |
| I-3373476 | Fittings - EM | R | 10/19/2022 | 121.31 | | 047941 | | |
| I-3373477 | Speedcore Bit & Expension - SA | R | 10/19/2022 | 118.80 | | 047941 | | 474.87 |
| 00894 | HOSE-MAN, INC. | | | | | | | |
| I-5298933-0001-05 | Pump Hose - PL | R | 10/19/2022 | 308.89 | | 047942 | | 308.89 |
| 00127 | INDUSTRIAL BOLT & SUPPLY | | | | | | | |
| I-235239-2 | Carbon Steel Hex Dies - PL | R | 10/19/2022 | 48.49 | | 047943 | | |
| I-236303-1 | Nuts & Bolts - PL | R | 10/19/2022 | 370.23 | | 047943 | | |
| I-236478-1 | Hex Cap - TP | R | 10/19/2022 | 72.24 | | 047943 | | 490.96 |
| 05811 | Instrument & Valve Services Co | | | | | | | |
| I-3794986 | Treks Power Cable - EM | R | 10/19/2022 | 418.27 | | 047944 | | 418.27 |
| 05799 | Jack Henry & Associates Inc. | | | | | | | |
| I-4094415 | RemitPlus Express - ADM | R | 10/19/2022 | 250.00 | | 047945 | | |
| I-4098257 | RemitPlus - ADM | R | 10/19/2022 | 1,000.00 | | 047945 | | 1,250.00 |
| 05744 | Kear Groundwater | | | | | | | |
| I-3038 | Hydrogeologic Services - HOBO | R | 10/19/2022 | 3,860.00 | | 047946 | | 3,860.00 |
| 01161 | LAKE CASITAS MARINA CAFE | | | | | | | |
| I-092522 | Employee Breakfast - WP | R | 10/19/2022 | 257.40 | | 047947 | | 257.40 |
| 00856 | MATTHEW BENDER & CO., INC. | | | | | | | |
| I-32394519 | CA Public Labor Relations - HR | R | 10/19/2022 | 605.02 | | 047948 | | 605.02 |
| 00151 | MEINERS OAKS ACE HARDWARE | | | | | | | |
| I-020269 | Tape & Xopper Pipe-L Hard - TP | R | 10/19/2022 | 68.76 | | 047949 | | |
| I-020419 | Rope - EM | R | 10/19/2022 | 9.36 | | 047949 | | |
| I-020657 | Hook Rope & Tiedown - UT | R | 10/19/2022 | 82.52 | | 047949 | | |
| I-020659 | Tarp Silver/Black - WP | R | 10/19/2022 | 214.69 | | 047949 | | |
| I-020674 | Bolts & Screws - MAINT | R | 10/19/2022 | 11.06 | | 047949 | | |
| I-020748 | Headlights & Cob Flashlight -P | R | 10/19/2022 | 102.45 | | 047949 | | |
| I-020754 | Mini Mats - LCRA | R | 10/19/2022 | 231.47 | | 047949 | | |
| I-020975 | Level Set - FISH | R | 10/19/2022 | 4.48 | | 047949 | | |
| I-021111 | Bolts & Screws - FISH | R | 10/19/2022 | 1.60 | | 047949 | | |
| I-021117 | Highline Parts - UT | R | 10/19/2022 | 154.95 | | 047949 | | |
| I-021118 | Corner Brace - UT | R | 10/19/2022 | 187.54 | | 047949 | | |
| I-021219 | Solid Wire & Fittings - EM | R | 10/19/2022 | 99.17 | | 047949 | | |
| I-021239 | Adapter - EM | R | 10/19/2022 | 24.57 | | 047949 | | |
| I-021332 | Adapter, Bolts & Screws - UT | R | 10/19/2022 | 52.26 | | 047949 | | 1,244.88 |

| VENDOR I.D. | NAME | STATUS | CHECK DATE | INVOICE AMOUNT | DISCOUNT | CHECK NO | CHECK STATUS | CHECK AMOUNT |
|---------------|--------------------------------|--------|------------|----------------|----------|----------|--------------|--------------|
| 03444 | Mission Linen Supply | | | | | | | |
| I-517957649 | Uniform Pants - MAINT | R | 10/19/2022 | 28.27 | | 047951 | | |
| I-517957652 | Uniform Pants - TP | R | 10/19/2022 | 52.09 | | 047951 | | 80.36 |
| 01570 | Ojai Auto Supply | | | | | | | |
| C-553815 | Core Deposit Return - Unit 55 | R | 10/19/2022 | 49.50CR | | 047952 | | |
| I-553808 | Starter - Unit 55 | R | 10/19/2022 | 187.28 | | 047952 | | 137.78 |
| 00165 | OJAI LUMBER CO, INC | | | | | | | |
| I-2209-705581 | Gray Spray Prime & Concrete | R | 10/19/2022 | 104.06 | | 047953 | | |
| I-2210-707004 | I-Beam Level - UT | R | 10/19/2022 | 39.98 | | 047953 | | |
| I-2210-707197 | Doug Fir - LCRA | R | 10/19/2022 | 61.40 | | 047953 | | 205.44 |
| 05713 | Pops Auto Repair | | | | | | | |
| I-0304 | E01- Insurance Repair | R | 10/19/2022 | 3,080.22 | | 047954 | | |
| I-0306 | Boom Truck - Unit 87 | R | 10/19/2022 | 800.00 | | 047954 | | |
| I-0309 | Electrical Wiring & Battery | R | 10/19/2022 | 1,500.00 | | 047954 | | 5,380.22 |
| 00184 | POWERSTRIDE BATTERY CO, INC | | | | | | | |
| I-V608167 | Battery - Unit 83 | R | 10/19/2022 | 105.04 | | 047955 | | 105.04 |
| 00790 | PROFORMA | | | | | | | |
| I-BI85008011A | Apply logo to Shirts - MAINT | R | 10/19/2022 | 177.79 | | 047956 | | |
| I-BI85008186A | Logo Hats & Jacket - MAINT | R | 10/19/2022 | 107.75 | | 047956 | | |
| I-BI85008280A | Safety Vest - PR | R | 10/19/2022 | 37.71 | | 047956 | | 323.25 |
| 10042 | PSR ENVIRONMENTAL SERVICE, INC | | | | | | | |
| I-11033 | SB989 - 1 UST - GARAGE | R | 10/19/2022 | 2,900.00 | | 047957 | | |
| I-11034 | LCRA UST SB989 - GARAGE | R | 10/19/2022 | 3,060.00 | | 047957 | | 5,960.00 |
| 00788 | QUINN COMPANY | | | | | | | |
| I-PC010424434 | Key - PL | R | 10/19/2022 | 81.06 | | 047958 | | 81.06 |
| 01172 | RP BARRICADE | | | | | | | |
| I-61853 | LED Micropulse Ultra - Unit 59 | R | 10/19/2022 | 457.31 | | 047959 | | |
| I-61854 | Safety Cones - PL | R | 10/19/2022 | 1,113.05 | | 047959 | | 1,570.36 |
| 01109 | SALVADOR LOERA TRANSPORTATION | | | | | | | |
| I-15842 | Fill Sand - LCRA | R | 10/19/2022 | 1,675.00 | | 047960 | | |
| I-188420 | Base for Main Yard - PL | R | 10/19/2022 | 750.00 | | 047960 | | |
| I-188422 | Base & Fill Sand - LCRA | R | 10/19/2022 | 1,372.00 | | 047960 | | |
| I-188436 | Base for Mutual Yard - PL | R | 10/19/2022 | 795.00 | | 047960 | | |
| I-188574 | Fill Sand for Mutual Yard - PL | R | 10/19/2022 | 572.00 | | 047960 | | |
| I-188575 | Fill Sand for Mutual Yard - PL | R | 10/19/2022 | 572.00 | | 047960 | | 5,736.00 |

| VENDOR I.D. | NAME | STATUS | CHECK DATE | INVOICE AMOUNT | DISCOUNT | CHECK NO | CHECK STATUS | CHECK AMOUNT |
|------------------|--------------------------------|--------|------------|----------------|----------|----------|--------------|--------------|
| 01107 | SAWYER PETROLEUM | | | | | | | |
| I-S144848 | Gas - LCRA | R | 10/19/2022 | 1,738.87 | | 047961 | | |
| I-S144849 | Diesel - LCRA | R | 10/19/2022 | 3,604.72 | | 047961 | | 5,343.59 |
| 04709 | Scheinberg Orthopedic Group | | | | | | | |
| I-6/16324598-1 | 1102WC200000006 DOS 07/27/22 | R | 10/19/2022 | 187.21 | | 047962 | | 187.21 |
| 06011 | Scoi Anesthesia Medical Corpor | | | | | | | |
| I-6/16386306-1 | 1102WC230300001 DOS 08/12/22 | R | 10/19/2022 | 204.86 | | 047963 | | |
| I-6/16389482-1 | 1102WC230300001 DOS 08/12/22 | R | 10/19/2022 | 134.72 | | 047963 | | 339.58 |
| 02597 | Shell | | | | | | | |
| I-83787724 | Diesel - LCRA | R | 10/19/2022 | 237.69 | | 047964 | | 237.69 |
| 02814 | Soilworks LLC | | | | | | | |
| I-20046 | Solitac - LCRA | R | 10/19/2022 | 2,534.13 | | 047965 | | 2,534.13 |
| 00048 | STATE OF CALIFORNIA | | | | | | | |
| I-101322 | State Water Plan Payment | R | 10/19/2022 | 257,400.00 | | 047966 | | 257,400.00 |
| 02703 | Sunbelt Rentals | | | | | | | |
| I-131156755-0001 | Rent Mini-Excavator - PL | R | 10/19/2022 | 2,461.42 | | 047967 | | 2,461.42 |
| 05779 | The Spine and Orthopedic Cente | | | | | | | |
| I-6/16334560-1 | 1102WC200000006 DOS 06/29/22 | R | 10/19/2022 | 133.54 | | 047968 | | |
| I-6/16461886-1 | 1102WC200000006 DOS 08/30/22 | R | 10/19/2022 | 182.95 | | 047968 | | 316.49 |
| 06012 | UCLA Ipn Scoi | | | | | | | |
| I-6/16347742-1 | 1102WC230300001 DOS 08/01/22 | R | 10/19/2022 | 303.01 | | 047969 | | |
| I-6/16382108-1 | 1102WC230300001 DOS 08/12/22 | R | 10/19/2022 | 868.50 | | 047969 | | |
| I-6/16395078-1 | 1102WC230300001 DOS 08/10/22 | R | 10/19/2022 | 35.04 | | 047969 | | |
| I-6/16399061-1 | 1102WC230300001 DOS 08/22/22 | R | 10/19/2022 | 11.89 | | 047969 | | |
| I-6/16414107-1 | 1102WC230300001 DOS 08/22/22 | R | 10/19/2022 | 136.66 | | 047969 | | 1,355.10 |
| 00891 | VENTURA COUNTY CLERK | | | | | | | |
| I-100422 | Notice of Exemption - ENG | R | 10/19/2022 | 50.00 | | 047970 | | 50.00 |
| 00258 | VENTURA STEEL, INC | | | | | | | |
| I-275091 | H.S.T 20" - ENG | R | 10/19/2022 | 336.77 | | 047971 | | |
| I-275530 | H.S.T 120" - ENG | R | 10/19/2022 | 153.37 | | 047971 | | |
| I-275658 | Steel for Valve Key - PL | R | 10/19/2022 | 291.72 | | 047971 | | 781.86 |
| 06009 | Vision Communications Company | | | | | | | |
| I-0756614A-IN | Vehicle Radios - SAFE | R | 10/19/2022 | 9,207.06 | | 047972 | | 9,207.06 |

| VENDOR I.D. | NAME | STATUS | CHECK DATE | INVOICE AMOUNT | DISCOUNT | CHECK NO | CHECK STATUS | CHECK AMOUNT |
|-------------------|--------------------------------|--------|------------|----------------|----------|----------|--------------|--------------|
| 01412 | AARON WALL | | | | | | | |
| I-Oct 22 | Reimburse Expenses 10/22 | R | 10/19/2022 | 879.83 | | 047973 | | 879.83 |
| 00277 | ZEE MEDICAL SERVICE CO. | | | | | | | |
| I-34-118505 | First Aid Kits - SAFE | R | 10/19/2022 | 1,090.96 | | 047974 | | 1,090.96 |
| 04010 | CALIFORNIA STATE DISBURSEMENT | | | | | | | |
| I-CS5202210172136 | 200000001181291 | R | 10/19/2022 | 386.30 | | 047975 | | 386.30 |
| 00102 | FRANCHISE TAX BOARD | | | | | | | |
| I-G03202210172136 | Payroll Deduction | R | 10/19/2022 | 815.40 | | 047976 | | 815.40 |
| 00124 | ICMA RETIREMENT TRUST - 457 | | | | | | | |
| I-DCI202210172136 | DEFERRED COMP FLAT | R | 10/19/2022 | 1,954.17 | | 047977 | | |
| I-DI%202210172136 | DEFERRED COMP PERCENT | R | 10/19/2022 | 110.69 | | 047977 | | 2,064.86 |
| 00985 | NATIONWIDE RETIREMENT SOLUTION | | | | | | | |
| I-CUN202210172136 | 457 CATCH UP | R | 10/19/2022 | 1,409.35 | | 047978 | | |
| I-DCN202210172136 | DEFERRED COMP FLAT | R | 10/19/2022 | 7,720.26 | | 047978 | | |
| I-DN%202210172136 | DEFERRED COMP PERCENT | R | 10/19/2022 | 423.09 | | 047978 | | 9,552.70 |

| * * T O T A L S * * | NO | INVOICE AMOUNT | DISCOUNTS | CHECK AMOUNT |
|---------------------|-----|-------------------|-----------|--------------|
| REGULAR CHECKS: | 140 | 724,215.97 | 0.00 | 724,215.97 |
| HAND CHECKS: | 0 | 0.00 | 0.00 | 0.00 |
| DRAFTS: | 9 | 167,164.78 | 0.00 | 167,164.78 |
| EFT: | 0 | 0.00 | 0.00 | 0.00 |
| NON CHECKS: | 0 | 0.00 | 0.00 | 0.00 |
| VOID CHECKS: | 0 | VOID DEBITS 0.00 | | |
| | | VOID CREDITS 0.00 | 0.00 | 0.00 |

TOTAL ERRORS: 0

| VENDOR SET: 01 | BANK: AP | TOTALS: | NO | INVOICE AMOUNT | DISCOUNTS | CHECK AMOUNT |
|----------------|----------|---------|-----|----------------|-----------|--------------|
| | | | 149 | 891,380.75 | 0.00 | 891,380.75 |
| BANK: AP | TOTALS: | | 149 | 891,380.75 | 0.00 | 891,380.75 |
| REPORT TOTALS: | | | 149 | 891,380.75 | 0.00 | 891,380.75 |

Adjudication Charge Fund Account

Publication of check register is in compliance with Section 53065.6 of the Government Code which requires the District to disclose reimbursements to employees and/or directors.

Adj. Checks: 000086

Voids:



Janyne Brown , Chief Financial Officer

| VENDOR I.D. | NAME | STATUS | CHECK DATE | INVOICE AMOUNT | DISCOUNT | CHECK NO | CHECK STATUS | CHECK AMOUNT |
|-------------------|--|--------|------------|----------------|----------|----------|--------------|--------------|
| 00194 I-101122 | City of Ojai Adjudication -kear Groundwater | R | 10/19/2022 | 896.00 | | 000086 | | 896.00 |

* * T O T A L S * *

| | NO | INVOICE AMOUNT | DISCOUNTS | CHECK AMOUNT |
|-----------------|----|----------------|-----------|--------------|
| REGULAR CHECKS: | 1 | 896.00 | 0.00 | 896.00 |
| HAND CHECKS: | 0 | 0.00 | 0.00 | 0.00 |
| DRAFTS: | 0 | 0.00 | 0.00 | 0.00 |
| EFT: | 0 | 0.00 | 0.00 | 0.00 |
| NON CHECKS: | 0 | 0.00 | 0.00 | 0.00 |
| VOID CHECKS: | 0 | | | |
| VOID DEBITS | | 0.00 | | |
| VOID CREDITS | | 0.00 | 0.00 | |

TOTAL ERRORS: 0

| | NO | INVOICE AMOUNT | DISCOUNTS | CHECK AMOUNT |
|----------------------------------|----|----------------|-----------|--------------|
| VENDOR SET: 01 BANK: ADJ TOTALS: | 1 | 896.00 | 0.00 | 896.00 |
| BANK: ADJ TOTALS: | 1 | 896.00 | 0.00 | 896.00 |
| REPORT TOTALS: | 1 | 896.00 | 0.00 | 896.00 |

Minutes of the Casitas Municipal Water District
Board Meeting Held
October 12, 2022

1. CALL TO ORDER

President Brennan called the meeting to order at 5:00 p.m.

2. ROLL CALL

Directors Bergen, Kaiser, Cole, Hajas and Brennan are present. Also present are GM Flood, AGM Dyer, EA Vieira and Counsel McNulty.

3. PLEDGE OF ALLEGIANCE

President Brennan led the Pledge of Allegiance.

4. AGENDA CONFIRMATION

The agenda was confirmed as submitted.

5. PUBLIC COMMENTS - Presentation on District related items that are not on the agenda - three minute limit.

There were no public comments.

6. CONSENT AGENDA

6.a. Accounts Payable Report.
[Accounts Payable Report.pdf](#)

6.b. Minutes of the September 28, 2022 Board Meeting.
[9 28 2022 Min.pdf](#)

6.c. Resolution re-authorizing remote teleconference meetings for the Legislative bodies of Casitas MWD for the period of October 12, 2022 to November 11, 2022. [Resolution Subsequent AB 361.pdf](#)

The consent agenda was offered by Director Kaiser, seconded by Director Bergen and adopted by the following roll call vote:

| | | |
|---------|------------|--------------------------------------|
| AYES: | Directors: | Bergen, Kaiser, Cole, Hajas, Brennan |
| NOES: | Directors: | None |
| ABSENT: | Directors: | None |

Resolution is numbered 2022-33

7. ACTION ITEMS

- 7.a. Discussion and possible action on the Casitas MWD Matilija Formation Groundwater Supply Vertical Bore Project (VRBO).
[Board Memo Discussion of Matilija Formation Vertical Bore Well 101222.pdf](#) [Verbo Project Description 121418 ATT1.pdf](#)
[TAC Outline and Memo for Matilija Fm Water Supply Project 110319 ATT2.pdf](#)

GM Flood provided information on the HOB0 project where we had difficulty obtaining a 299 permit from the Forest Service to place monitoring devices on the creeks. In 2019 Pueblo Water Resources was engaged to look at feasibility of the project for the VRBO. A technical advisory committee issued a summary report stating there should be more information before commencing on the project. Almost \$200,000 has been spent at that point and the board decided to put it on the watch list. Since then staff has been looking at possibilities of getting grant funding for the bore for the preliminary estimates of \$2 million dollars to test the water quality and quantity. The project was expected to get 8,000 af. With wells you don't know until you drill so there is a risk. Staff recommends we continue to chase funding for a pilot bore to make the assessment about going forward with the project.

Director Kaiser, Cole and Brennan are supportive of continuing to seek grants with Director Cole suggesting we seek funding for the entire project. If the drilling does not yield water then the project can be killed.

Director Hajas was not as enthusiastic as we do not have any answers to the questions the technical team brought forward. Public money should not be used for speculation and wildcat drilling. It detracts from real projects.

Director Bergen added it is a risky project which is why it has been percolating along. The initial information came from Jordan Kear and was based on the Tecelote tunnel. I see it as another emergency supply. Only used occasionally but it could give our Health & Safety water we need. We won't know unless we spend the money to find out. What other sources of HS water do we have?

Direction was provided to staff to continue to explore funding on the project including incorporating the issues the TAC committee raised and have it all included in one project for the full amount.

- 7.b. Approval of proposals from Kennedy-Jenks Engineers to assist with preparation of State of California 2022 Urban Drought Communities Grant Applications in the minimum total grant award amount of \$10,000,000 and Adopt Resolutions in support of same:

a. Approve a proposal for assistance with the 2022 Urban Drought Communities Grant Application for the Matilija Formation Groundwater

Supply Vertical Bore Pilot Project (VRBO) in the amount of \$13,500 and adopt the supporting resolution.

b. Assistance with the 2022 Urban Drought Communities Grant Application for Groundwater Interconnections Project in the amount of \$34,260 and adopt the supporting resolution.

[Board Memo Resolutions and KJ Grant Assistance Proposals](#)

[101222.pdf Casitas Draft Res 2022 Urban Communit](#)

[Drought - VRBO 101222 ATT1.pdf](#)

[Casitas Draft Res 2022 Urban Communit](#)

[Drought - GW Connections](#)

[ATT2.pdf Proposal for Casitas2022UrbanDrought Communities](#)

[Matilija Deep Vertical Bore 101222 ATT3.pdf](#)

[Proposal for Casitas2022UrbanDrought GW Connections 101222 ATT4.pdf](#)

GM Flood explained there were changes in the report on Monday and the new minimum is \$3 million.

The resolutions were offered by Director Kaiser, seconded by Director Cole and adopted by the following roll call vote:

| | | |
|---------|------------|-------------------------------|
| AYES: | Directors: | Bergen, Kaiser, Cole, Brennan |
| NOES: | Directors: | Hajas |
| ABSENT: | Directors: | None |

Resolutions are numbered 2022-34 and 2022-35

7.c. Approval of a funding agreement with the City of Ventura for the State Water Project Interconnection project for funding of design and an unbudgeted item in the amount of \$550,000 for Fiscal Year 2022-2023.

[Board Memo_Caleguas Ventura Interconnection 10.12.2022.pdf](#)

[ATT1. Draft_Casitas_City_Funding Agreement for SWP Interconnection Design.pdf](#)

GM Flood explained that Casitas staff worked out a simple letter agreement but have not sought feedback yet from the City of Ventura. It is a straightforward proposal agreement where we fund that project in this amount and they allow us to have input on the project design.

Director Bergen questioned what we are expecting to get out of this on the input of the design. GM Flood responded this is the first step in committing to the project – this funding allows time to look at the agreements necessary to finish the project including the exchange agreement and a funding decision after that. \$550,000 shows the board believes in the project and it is worthwhile funding at this point but not funding the entire project at this point.

Director Cole explained that he sees the \$550,000 getting us input on the design

and the final costs etc. and we have the ability to negotiate the in lieu agreement. If we are not partners I don't see why the city would buy water from us. I see the overall project as great for the region and it will help Casitas a little bit.

Director Hajas asked about grant funding with GM Flood explaining that we are not the lead agency. Director Hajas supports the project and it will have regional benefits long beyond when we are on this board. It is a huge mistake to forfeit this opportunity.

Director Kaiser liked the regional aspect of getting water conveyed and asked about the ability to utilize the conservation penalty reserves for this. Mr. McNulty explained this is an appropriate use of the funds. Ensuring the contract is clear that the \$550,000 is a not to exceed amount with no guarantee for future funding was discussed as well.

Bruce Kuebler strongly supports this as it is past the time to commit to working with Ventura.

Burt Handy questioned having a cost study analysis of SB vs. Calleguas/Ventura in lieu agreement. Maintenance costs should be included and a comparison of costs reviewed for a decision on this issue.

Direction was provided to staff to work on the agreement with the attorney and share with the City and then bring back to the Board.

- 7.d. [Award LCRA Paving at Campground Fox, Specification No, 22-454 to BC Rincon Construction in an amount not to exceed \\$141,677.44.](#)
[Board Memo for LCRA Paving Award 101222.pdf](#)

On the motion of Director Kaiser, seconded by Director Cole the above recommendation was passed by the following roll call vote:

| | | |
|---------|------------|--------------------------------------|
| AYES: | Directors: | Bergen, Kaiser, Cole, Hajas, Brennan |
| NOES: | Directors: | None |
| ABSENT: | Directors: | None |

8. DISCUSSION ITEMS/PRESENTATIONS

- 8.a. Update on Casitas MWD Administration Building roof replacement/solar project.

Site Logic provided an update on the roof replacement/solar project with GM Flood explaining that funding is his concern. The project will provide roof replacement, solar and LED retrofits at various locations. The roof would have a 30 year warranty. Return on Investment would be approximately 15 years. The maintenance for the solar panels is not included in the price but the maintenance could be contracted with Site Logic. There could be grant funding or rebates available. A discussion regarding electric charging

stations was also discussed.

Burt Handy asked about moving roof antennas, putting in charging stations at Lake Casitas, upgrade to LED lighting and looking to place solar on top of the dam.

GM Flood advised this was just for information purposes at this point and a contract and resolution could be brought back to the board at a later date for consideration.

9. INFORMATION ITEMS

- 9.a. State Water Project Intertie Report.
[SWP Intertie Project Cost 9-30-22.pdf](#)
- 9.b. CFD 2013 Report.
[CFD 2013-1 Project Cost 9-30-2022.pdf](#)
- 9.c. Investment Report.
[Investment Report 9.30.22.pdf](#)
- 9.d. Adjudication Charges Report.
[Adjudication Charges YTD 9.30.22.pdf](#)
- 9.e. Consumption Report August.
[Consumption 2022-2023.pdf](#)
- 9.f. Financial Statements for June 2022.
[Financial Statements 06-30-2022 Summary Final.pdf](#)
- 9.g. Financial Statement for July 2022.
[Financial Statements 07-31-2022 Summary.pdf](#)

The information items were received.

10. GENERAL MANAGER COMMENTS

GM Flood mentioned the Ag Town Hall would be on Thursday October 20th at the Park and Resource center.

Water security tours are scheduled for October 29th and November 5th. Two directors have spots. If anyone else wants to go we need to know ASAP as we have a waiting list.

11. BOARD OF DIRECTOR REPORTS ON MEETINGS ATTENDED

President Brennan attended the special district meeting and the AWA Board Meeting. Director Bergen listened to the VRWC meeting.

12. BOARD OF DIRECTOR COMMENTS PER GOVERNMENT CODE SECTION 54954.2(a).

None

President Brennan moved the meeting to closed session at 6:14 p.m.

13. CLOSED SESSION

- 13.a. CONFERENCE WITH LEGAL COUNSEL – EXISTING LITIGATION
(Government Code Section 54956.9(a) Santa Barbara Channelkeeper v. State Water Resources Control Board, City of San Buenaventura, et al.; and City of San Buenaventura v Duncan Abbott, et al., Cross Complaint; Superior Court of the State of California, County of Los Angeles, Case No. 19STCP01176.

Vice President Hajas moved the meeting back into open session at 6:28 p.m. with Mr. McNulty stating the board met in closed session and there was no reportable action taken.

14. ADJOURNMENT

Vice President Hajas adjourned the meeting at 6:29 p.m.

Neil Cole, Secretary

**CASITAS MUNICIPAL WATER DISTRICT
MEMORANDUM**

TO: BOARD OF DIRECTORS
FROM: MICHAEL FLOOD, GENERAL MANAGER
SUBJECT: DISCUSSION AND POSSIBLE ACTION ON A DRAFT STATE WATER
PROJECT WATER SUPPLY EXCHANGE AGREEMENT WITH THE CITY OF
VENTURA
DATE: 10/21/2022

RECOMMENDATION:

Approve the draft State Water Project (SWP) Water Supply Exchange Agreement with the City of Ventura as presented and instruct staff to bring back the SWP Interconnection Cooperative Agreement for Review.

BACKGROUND:

In January 2017, the Casitas MWD Board of Directors passed a motion dedicating \$200,000.00 to the development of the feasibility study of a regional water infrastructure project to deliver State Water Project water supplies to Western Ventura County.

The project partners are Calleguas MWD, the City of Ventura, the United Water Conservation District, and Casitas MWD.

The alignment study and EIR was developed by Kennedy-Jenks Engineers over the following 2-1/2 years at a cost of \$115,142.20 to Casitas.

In June 2021, the Board requested a discussion on the costs and benefits of two State Water Interconnection projects that the District has been considering: the Ventura-Santa Barbara Counties Intertie Project and the Calleguas-Ventura Interconnection Project.

The topic was discussed further during the Special Board Meeting of July 27, 2021 with the Board providing staff with direction to bring back information on a possible Exchange Agreement with the City of Ventura that would be required for Casitas to receive a benefit from the project.

Casitas staff met with the staff of Ventura Water in September 2021 to discuss the various aspects of an Exchange Water Delivery arrangement between the two agencies.

The Ad-Hoc Imported Water Projects Committee was subsequently assigned to review and negotiate an Exchange Agreement with the City of Ventura.

At the September 28, 2022 Casitas MWD Board Meeting, Casitas staff presented a white paper reviewing various aspects of alternative water supply projects including the Calleguas-Ventura SWP Interconnection Project.

During the October 12, 2022 Casitas MWD Board Meeting, Casitas staff indicated that an exchange agreement involving Casitas MWD and the City of Ventura would be brought back to the next Casitas MWD Board Meeting.

DISCUSSION:

As part the decision-making process on future District funding of the Calleguas-Ventura SWP Interconnection Project with the City of Ventura, the Casitas MWD Board has requested that the benefits of District funding of the project be identified through a water exchange agreement with the City of Ventura.

This water exchange agreement would enable Casitas to require the City of Ventura to take water service through the SWP Interconnection with the goal of saving local water supply in Lake Casitas.

Aspects of the Draft Exchange Agreement with the City of Ventura:

- Thirty-year term with renegotiation possible after ten years.
- Exchange delivery of only Casitas' State Water Project Table A allocation.
- Exchange supplies are subject to Casitas' WEAP restrictions.
- The City of Ventura would reduce its demands from Lake Casitas in a like amount of the exchange water that is delivered.
- Water supply delivered from the Calleguas-Ventura SWP Interconnection would only be used for any supplemental supply that is needed within the in-District area (i.e. Casitas boundaries) of the City's water system. The City will calculate/report the water balance as it currently does in its Water Service Agreement with Casitas.
- The City of Ventura will pay the Casitas Resale Gravity Volumetric water rate in place at the time for exchange delivery of Casitas' State Water Project Table A supply. The City Staff have indicated that it is unwilling to accept any other arrangement in regard to this cost.
- Water loss calculation capped at 6.5% for any particular year.
- When Lake Casitas is less than 50% full, Casitas can require that the City take Exchange Water Supplies through the Interconnection which increases as the water level in Lake Casitas decreases.
- Casitas has the ability to audit the City's records in connection with this agreement.

Cost Considerations from the Exchange Agreement:

- Casitas MWD would pay the cost difference between the Casitas Resale Volumetric Rate and the various wheeling and State Water Project (SWP) variable costs in this arrangement, estimated at approximately \$1,200 to \$1,500 per Acre-Foot at this time.
- SWP and wheeling costs to deliver water through this project can be expected to increase significantly in the future and Casitas' water rates will need to be adjusted accordingly.

BUDGETARY IMPACT:

Assuming the approval of this agreement as currently written, Casitas would be responsible for the costs to deliver this water supply to the City of Ventura, over and above the Casitas volumetric gravity rate in place at the time.

Casitas MWD's water rate study would need to take this into account to adjust water rates for all Casitas' customers including resale customers like the City of Ventura.

NEXT STEPS:

With the approval of the Exchange Agreement, the Casitas Board should review the SWP Interconnection Cooperative Agreement that involves the rights and responsibilities of the parties (Calleguas MWD, United WCD, City of Ventura, and Casitas) for the design, construction, operation and maintenance of the SWP Interconnection Project.

CONCLUSION:

With the Exchange Agreement in place, Casitas' participation in the Calleguas-Ventura SWP Interconnection Project would have a defined benefit through the ability to conserve local water supplies in Lake Casitas during times of drought.

Approval of the Exchange Agreement should be followed with a Casitas Board review of the SWP Interconnection Cooperative Agreement.

**Exchange Agreement for Delivery of State Water Supplies within the In-District Service Area of the
City of Ventura**

This agreement made this _____ day of _____, 2022, between the City of San Buenaventura, a California charter law municipal corporation, hereafter referred to as the “City”, and the Casitas Municipal Water District, a California special district, hereafter referred to as “Casitas”. The City and Casitas shall collectively be referred to herein as the “Parties”.

RECITALS

- A. Whereas, in 1971 Casitas assumed the Ventura County Watershed Protection District’s contract with the State of California Department of Water Resources contract for delivery of 20,000 Acre-Feet of State Water Project water; and
- B. Whereas, Casitas subcontracted 10,000 Acre-Feet of the State Water Project water to the City; and
- C. Whereas, Casitas retained the contract to 5,000 Acre-Feet of the State Water Project water supply; and
- D. Whereas, through their participation in the State Water Project contract Casitas and the City have rights to deliver imported water supplies in varying amounts from year to year through the State Water Project; and
- E. Whereas, the City intends to construct pipelines and other distribution system improvements that would allow State Water deliveries from the eastern side of the City to offset the City’s use of Lake Casitas water. These projects are referred to by the City as the Eastside to Midtown Interconnection Project and the Midtown to Westside Interconnection Project. Even with these projects completed, the City will not have facilities capable of supplying water to the northwesterly portion of the City’s Casitas service area (referred to as the 400-foot pressure zone). Therefore, in times that Ventura River cannot supply water to these customers, the City does depend entirely on water from Lake Casitas to serve customers in the 400-foot pressure zone; and
- F. Whereas, Casitas is limited in its local supplies and intends to enter into this agreement in order to extend the life of those supplies; and
- G. Whereas, Casitas and the City seek to develop an agreement that allows for the delivery of imported water supplies into Casitas’ in-District area of the City that will be in exchange of the City’s demands from Casitas’ local supplies; and

- H. Whereas, the parties acknowledge that cooperative management of regional water resources can be achieved through coordinated and joint management activities; and
- I. Whereas, Casitas and City will enter into separate wheeling agreements with MWD and Calleguas to convey SWP Water through MWD and Calleguas facilities to the new interconnection pipeline; and
- J. Whereas, Casitas and City will enter into a separate agreement with United WCD and Calleguas MWD that sets forth the terms by which each party will cooperate in the financing, design, construction, operation and maintenance of the Interconnection Project; and
- K. Therefore, Casitas and the City enter into this agreement with aforementioned goal of retaining local water supplies through delivery of imported water supplies for exchange.

Article 1
Definitions

- 1.1 Actual In-District Demand: The water purchased from Casitas and utilized by the City within Casitas' boundaries for in-District use as certified by the City on an annual basis, as per Article 5 in this agreement.
- 1.2 Fiscal Year: The period from July 1st of the current year to June 30th of the following year for each year of the contract.
- 1.3 Casitas' SWP Water: Table A water from Casitas' SWP allotment, Article 56 water belonging to Casitas and delivered from San Luis Reservoir, or Casitas' available imported water from transfers or exchanges with other State Water Project contractors.
- 1.4 Interconnection Project: The interconnection pipeline to the Calleguas MWD system that conveys water to the City of Ventura's service area. The Interconnection includes all facilities and reaches, including pipeline, pressure reducing stations, meters, and the physical interconnection itself.
- 1.5 Lake Casitas Capacity: Related to elevation of lake, and equals a percentage of total lake capacity, including dead storage.
- 1.6 Purchased Water: Water purchased by the City from Casitas as determined by City and Casitas meters. This includes both imported supplies and Casitas MWD local supplies.
- 1.7 State Water Project Table A Water: Imported water supply from the California State Water Project as enumerated in Table A "ANNUAL ENTITLEMENTS VENTURA COUNTY FLOOD CONTROL DISTRICT" of the California Department of Water Resources water supply contract and further enumerated in the related agreements between the City of Ventura, the United Water Conservation District and Casitas MWD.

1.8 State Water Project Article 56 Water: State Water Project Water Supply as defined in Article 56 of the California Department of Water Resources water supply contract as relates to supplies owned and controlled by Casitas.

1.9 Water Loss: The ratio of water lost from systems operations, non-revenue water, leaks, etc. Water Loss shall be determined based on the following annual fiscal-year calculation:

$$\text{Water Loss} = (\text{Citywide Water Production} - \text{Citywide Metered Sales}) / \text{Citywide Water Production}$$

This Water Loss calculation will be made each year by the City and may be revised to meet State-prescribed definitions and/or standards. **For the purposes of this agreement, Water Loss shall not exceed 6.5% within Casitas' In-District boundaries.**

Article 2 Term

2.1 Term of Agreement: This Agreement shall be in effect for 30 years from the date of its adoption by both Parties, except as identified below in 2.2. It is subject to extension by mutual consent of both Parties.

2.2 Renegotiation of key elements: After ten years, during calendar year 2032, either Party may request in writing to renegotiate key elements of the Agreement. Upon receiving this request, the other Party must enter negotiations in good faith on the key elements identified by the requesting Party. The Parties will have one year from the date of the initial request to renegotiate all identified key elements and adopt a revised Agreement. If, after one year, there is no agreement on all key elements, the original requesting Party may give notice to the other Party that they wish to enter into Mediation (see Article 8.7).

2.3 Other renegotiation: Should both Parties, by mutual consent, agree to renegotiate one or more key terms, they may do so, with no time limit on this negotiation. If both Parties agree on revisions, they may adopt a revised Agreement with the new terms. Under this section, with both Parties mutually agreeing to renegotiate, neither Party may terminate the Agreement except as provided herein.

Article 3 Scheduling and Delivery of Exchange Water Supplies

3.1 Casitas will decide on the delivery schedule of Casitas' SWP water, with input from the City. Scheduling of water supply for exchange will occur at least sixty (60) days prior to July 1st of the fiscal year in which those supplies will be delivered.

3.2 The City will use exchange water supplies to offset their Actual In-District Demand of Casitas' other supplies in like amounts.

- 3.2.1 The City will certify the actual amount Casitas' other supplies that have been offset within District no later than August 31st for the previous fiscal year.
- 3.2.2 Casitas will verify the actual amount of Casitas' other supplies that have been offset no later than 60 days subsequent to the City's certification.
- 3.3 SWP Limits: Under no circumstances may the exchange water delivered by Casitas to Ventura in any year exceed available Casitas' SWP water, in accordance with the annual delivery amounts determined by Casitas. Casitas, at its sole discretion, may determine if it wishes to sell Article 56 water to the City in any year.
- 3.4 Minimum Exchange Delivery Requirements: In order to preserve the level of Lake Casitas, City agrees to purchase exchange water from Casitas through the Interconnection in exchange of taking deliveries from Lake Casitas. Casitas will decide on the delivery schedule of this water, with input from the City and will depend on the availability of imported water as well as the ability of the other agencies to deliver the water. The minimum percentage of in-District demands to be purchased through the Interconnection Project by the City, if Casitas' SWP water supply is available, will be defined by the level in Lake Casitas, as defined below:
- 3.4.1. Lake Casitas at 50% or Higher: No Exchange Requirement.
- 3.4.2. Lake Casitas at 50% to 40%: City must purchase up to 50% of its estimated in-District demands, as requested by Casitas, through the Interconnection.
- 3.4.3. Lake Casitas at 40% to 30%: City must purchase up to 60% of its estimated in-District demands, as requested by Casitas, through the Interconnection.
- 3.4.4. Lake Casitas 30% to 20%: City must purchase up to 75% of its estimated in-District demands, as requested by Casitas, through the Interconnection.
- 3.4.5. Lake Casitas Below 20%: City must purchase up to 80% of its estimated in-District demands through the Interconnection, or the maximum potential exchange purchase, excepting the City's 400-foot zone if supply from Ventura River is not adequate.
- 3.5. Maximum Exchange Delivery for In-District Demands: The volumes defined in Section 3.4 are minimum values. In any year, the City and Casitas may mutually agree to deliver additional Casitas exchange water through the Interconnection. Notwithstanding anything in this agreement, the City's total purchases from Casitas will be subject to WEAP allocations for demand management purposes. The limit of total water delivered from all water sources by Casitas to Ventura in any year shall be the City's Actual in-district demand in that year. Should deliveries to the City exceed its calculated Actual in-District demands for that year, the City agrees to reduce its demand on Casitas Municipal Water District sources by a like amount over the next year. The City will provide records to Casitas upon completion of the demand reduction.
- 3.6. Casitas Exchange Delivery Opt-Out Provision: In any consecutive five-year period, Casitas shall have the option of opting out of this Agreement for up to one year. In that year, Casitas will make no

water available to City through the Interconnection. In these years, Casitas will notify City no later than March 1 of its intent to opt out, and all water sold to City in that year shall be from Lake Casitas.

Article 4
Costs of Delivery of Exchange Supplies

- 4.1 Casitas will pay all delivery costs, including DWR variable OMP&R costs, wheeling costs, and other costs associated with delivery, for all water sold to the City under this Agreement.
- 4.2 The City will be responsible to pay Casitas the then in place Casitas Resale Gravity Volumetric rate for the delivery of exchange water supplies.
- 4.3 Costs of a particular exchange transaction will be reconciled by the June 30th of the subsequent fiscal year.
- 4.4 If the requirements of Section 3.5 cannot be met, for any of Casitas' water delivered to the City that exceeds In-District demands, the City shall reimburse Casitas:
 - 1) The volume of water through a State Water Project transfer; and
 - 2) All variable delivery costs associated with said water, including wheeling charges and any other costs that are incurred based on the amount of water delivered.

The City shall be allowed the subsequent two years to complete this requirement.

Article 5
Certification Procedures

- 5.1 The City shall annually certify whether it achieved Water Balance. The certification shall identify Purchased Water, Actual In-District Demand, and Water Loss. The City shall provide its Annual Certification no later than the last business day of August. The Annual Certification shall cover the period of July 1 to June 30 of each fiscal year. The City will use its best efforts to accurately calculate Actual In-District Demand and Water Loss. The Parties agree to the following calculation for determining Water Balance:

Water Balance = Purchased Water - Actual In-District Demand - Water Loss

Water Balance: The City achieves Water Balance when the above calculation equals a negative number or zero.

Article 6
Verification and Audit Procedures

- 6.1 Casitas will review Ventura's Certification information to ensure the exchange water is being used in-District.

6.2 The City shall allow Casitas access to metering equipment for purposes of monitoring and inspection.

6.3 The City will provide sufficient detail in order for Casitas to audit transactions under this agreement including access to the City's records.

Article 7
Modification

7.1 No alteration, change, or modification of the terms of this Agreement shall be valid unless made in writing and signed by both Parties hereto and approved by appropriate action of the governing bodies of the Parties.

Article 8
General Provisions

8.1 CEQA

The Parties will be individually responsible for compliance with CEQA (if any) as required by law or their agency's internal requirements.

8.2 Indemnification

The Parties agree to defend, indemnify, and hold harmless each other including its officers, agents and employees, from and against any and all liability, damages, costs, losses, claims, and expenses, however caused, resulting directly or indirectly from or connected with the negligent performance of the Agreement (including, but not limited to, such liability, cost, damage, loss, claim, or expense arising from the death of or injury to, or damage to property of each Party or their respective employees or agents), except to the extent that such liability, damages, costs, losses, claims, or expenses are caused by the negligent or wrongful acts or omissions of each Party or any of each Party's agents or employees.

8.3 Entire Agreement

This writing embodies the entire agreement and understanding between the Parties hereto, and there are no other agreements and understandings, oral or written, with reference to the subject matter hereof that are not merged herein and superseded hereby, it being the intent of the Parties that neither shall be bound by any terms, conditions, or representations not written here.

8.4 Notices

All notices given or required to be given pursuant to this Agreement shall be in writing and may be given by personal delivery, mail, or email if the email is followed by mail. Notices sent by mail shall be addressed as follows:

To City:

City of San Buenaventura
Attention: City Manager

P.O. Box 99
Ventura, CA 93002-0099
Phone No: (805)
FAX No.: (805)
Email:

To Casitas:

Casitas Municipal Water District
Attention: General Manager
1055 Ventura Avenue
Oak View, CA 93022
Phone No: (805) 649-2251
FAX No.: (805) 649-3001
Email: mflood@casitaswater.com

When addressed in accordance with this paragraph, notice shall be deemed given upon deposit in the United States mail, postage prepaid. In all other instances, notices shall be deemed given at the time of actual delivery. Changes may be made in the titles or addresses of the persons to whom notices are to be given by giving notice in the manner prescribed in this paragraph.

8.5 Representation of Authority

Each Party represents and warrants to the other that the execution and delivery of this Agreement and the performance of such party's obligations hereunder have been duly authorized and that the Agreement is a valid and legal agreement binding on such parties and enforceable in accordance with its terms.

8.6 Invalidity and Severability

If any portion of this Agreement is declared invalid, illegal, or otherwise unenforceable by a court of competent jurisdiction, the remaining provisions shall continue in full force and effect.

8.7 Mediation

Unless otherwise agreed in writing, if the Parties cannot agree upon a resolution of the key elements of the agreement within one year of the request noted in Section 2.2, the dispute shall be submitted to mediation prior to commencement of any legal action or termination of the Agreement. The following elements shall apply to said Mediation:

- Mediation shall be no less than one (1) full day (unless agreed otherwise by the Parties).
- Cost of the mediation shall be paid in equal proportion between the Parties.
- The mediator shall be agreed to by the Parties or appointed by the Superior Court of California upon a suit or motion for appointment of a neutral mediator.

Upon completion of mediation pursuant to this Article 8.7, if the controversy has not been resolved, any party may exercise option for termination or other legal action under this Agreement by serving a Notice of Termination.

DRAFT

**CASITAS MUNICIPAL WATER DISTRICT
MEMORANDUM**

TO: BOARD OF DIRECTORS
FROM: MICHAEL L. FLOOD, GENERAL MANAGER
SUBJECT: APPROVAL OF REVISED CASITAS MWD RESERVE POLICY

DATE: 10/21/2022

RECOMMENDATION:

- Approve revised Casitas MWD Reserve Policy as presented

BACKGROUND:

Changes to the Casitas Reserve Accounts necessitate some changes to the Casitas Reserve Policy.

The Finance Committee reviewed the revised policy at their October meeting and recommended passing the revised policy to the Board of Directors for discussion and possible approval.

DISCUSSION:

Changes to the Casitas MWD Reserve Policy;

- Safe Drinking Water Reserve: This reserve was for payments in relation to the acquisition of the Mira Monte water system. This obligation has been paid off thus this reserve account has been removed
- OPEB Reserve: Moved from Unrestricted to Restricted reserve type. Funds are currently held in a trust account.
- Adjudication Funds Reserve: Added as a result of the funds being collected from customers as a result of an additional service charge added in 2020.
- Cash Flow Reserve: Name change to Operating Reserves. Target level set at 25% of Operations Budget.
- Variation in Water Sales: language added that outline when funds will be added or removed from the account based on budgeted revenues vs. actual revenues
- Capital Reserve: Language added to the Target Level that the reserve level will be further reviewed once Capital Planning is nearer to completion.

FINANCIAL IMPACT:

No direct financial impact is anticipated at this time as a result of the revised policy.



Draft Reserve Policy

October XX, 2022

Purpose

A key element prudent financial planning is to ensure that sufficient funding is available for current operating, capital, and debt service needs. Additionally, fiscal responsibility requires anticipating the likelihood of, and preparing for, unforeseen events. Casitas Municipal Water District (“District” or “CMWD”) will strive to have sufficient funding available to meet its existing operating, capital, and debt service obligations in a manner consistent with its Operating Budget and Capital Spending Plan. The District has established reserves for operational stability and for future capital needs in order to minimize significant rate fluctuations due to unforeseen and unexpected cash flow requirements. Reserves may be designated for specific purposes with minimum balances consistent with statutory obligations. The Reserve Policy is intended to ensure that the District has sufficient funds to meet current and future needs.

General Provisions

The District maintains the reserves in separate designated accounts within its accounting system in a manner that ensures financial soundness and provides transparency. Maintaining reserves at appropriate levels is a prudent, ongoing business process that consist of regular assessment and application of various funding alternatives. Either alone or in combination with each other, these alternatives may include rates, loans and grants, debt financing, investment of funds, and levels of capital expenditures.

The Board of Directors along with the General Manager will be responsible for managing the reserves. The Board must authorize all the expenditures for the reserve funds and approve any reallocation of funds or any transfers among the reserves. The balance of the reserves will be reviewed annually to evaluate the goals and propose of each reserve and make adjustments as necessary.

Definitions

Restricted Reserves: Restrictions on the use of these funds are imposed by an outside source such as creditors, grantors, contributors, laws or regulations governing use.

Unrestricted Reserves: These funds have no externally imposed use restrictions. The use of unrestricted funds is at the discretion of the Board. Unrestricted funds are designated for a specific purpose, which is determined by the board. The Board has authority to redirect the use of these funds as needs change.

District Specific Reserves

The District maintains the following reserves:

Restricted

Bond/Debt Service Reserves:

1. Safe Drinking Water Reserve

- ~~• Purpose and use of reserves- Established as a condition of each bond issue. The funds are legally protected by bond covenants and can only be used in the event of default by the District or to pay down principal and interest. May be used by the Trustee if the amounts in the bond fund are insufficient~~
- ~~• Target Level- The bond reserve requirement is established at the time of bond issue and can be recalculated as the bonds are paid down.~~

Unspent Bond Proceeds:

1. CFD 2013-1 Improvement Fund

- Purpose- Established as a condition of each bond issue. The funds are restricted for use designated in the bond's Official Statement.
- Use of reserves- May be used as designated in the official statement which include costs incurred to plan, design, engineer, finance, supervise, construct, and install, inspect, and obtain necessary permits for the purchase, construction, improvement, or rehabilitation to property or facilities within the CFD boundaries

Capital Reserves:

1. Capital Facilities Reserve

- Purpose and use of reserves- Funds are used to fund capital projects or the rehabilitation, enhancement or replacement of capital assets as they reach the end of their useful life. Staff recommends capital projects during the annual budget process and as these projects are approved, funds are appropriated from reserve funds or available revenues.
- Target Level- No specific target level. The District may set aside capital moneys for replacement funds on a project-by-project basis.

Other Post-Employment Benefits (OPEB)

- Purpose and use of reserves- Non-pension benefits provided to employees after employment ends and includes health insurance coverage for retirees and their families. The District currently funds OPEB on a pay-as-you-go basis, paying an amount annually equal to the benefits distributed or claimed that year. If necessary funds can be used to pay down the District's obligations.
- Target Level- No specific target level.

Adjudication:

1. Adjudication Funds Reserve

- Purpose and use of reserves - Funds collected through charges to customer water bills that fund costs of Adjudication.
- Target Level - No specific target level.

Unrestricted

Operational Reserves:

1. ~~Cash Flow Reserve~~ Operating Reserves

- Purpose and use of reserves- This reserve may be routinely utilized by staff to cover temporary cash flow deficiencies caused by timing differences between revenue and expenses, unexpected decreases in revenues and increase in expenses, and to fund improvement capital projects.
- Target Level- ~~Funding for this reserve fluctuates based on the revenue received from water sales.~~ 25% of the operations budget

~~2. Other Post-Employment Benefits (OPEB)~~

- ~~• Purpose and use of reserves- Non-pension benefits provided to employees after employment ends and includes health insurance coverage for retirees and their families. The District currently funds OPEB on a pay as you go basis, paying an amount annually equal to the benefits distributed or claimed that year. If necessary funds can be used to pay down the District's obligations.~~
- ~~• Target Level- No specific target level.~~

Emergency Reserves:

1. Storm Damage

- Purpose and use of reserves- This reserve may be used to cover temporary cash flow deficiencies related to maintenance and repair activities related to storm damage.
- Target Level- No specific target level.

2. Variation in Water Sales

- Purpose and use of reserves- - This reserve may be utilized to cover temporary cash flow deficiencies caused by reduction in water sales.
- Target Level- No specific target level but will staff will recommend funds be added when there are excess water sales revenues and removed when water sales revenues are deficient.

Capital Reserves:

1. Capital ~~Improvements~~ Replacement

- Purpose and use of reserves- Funds are used to make improvements to existing infrastructure. Staff recommends improvement projects during the annual budget process and as these projects are approved, funds are appropriated from reserve funds or available revenues.
- Target Level- No specific target level. When the capital replacement schedule is completed a specific target level can be set by the District to fund future projects. The District may set aside capital moneys for replacement funds on a project by project basis.

2. Alternate Water Supply Study

- Purpose and use of reserves- This reserve may be used for costs associated with alternate water supply development and acquisition.
- Target Level- No specific target level.

3. Conservation Penalty

- Purpose and use of reserves- Established to accumulate funds received from customers for penalties associated with consumption. This reserve may be utilized to cover costs associated with conservation activities and water supply development and acquisition.
- Target Level- Funding for this reserve fluctuates based on the revenue received from conservation penalties.

**CASITAS MUNICIPAL WATER DISTRICT
MEMORANDUM**

TO: BOARD OF DIRECTORS
FROM: MICHAEL FLOOD- GENERAL MANAGER
SUBJECT: REVIEW STAFF RECOMMENDATION TO SET CASITAS MUNICIPAL WATER DISTRICT RESERVE ACCOUNT AMOUNTS FOR THE 2022/2023 FISCAL YEAR
DATE: 10/21/2022

RECOMMENDATION:

Recommend the Board of Directors set reserves for the 2022/2023 fiscal year as recommended.

DISCUSSION:

Reserves for the fiscal-year-end 2021/2022 are calculated as follows:

Restricted:

Capital Facilities - Has been increased from \$159,641 to **\$322,327** a total of \$162,686.

Safe Drinking Water- Has been removed.

CFD 2013-1Improvement Fund- Has been reduced from \$9,917,331 to **\$6,819,665** a total of \$3,097,666.

Adjudication Fund- Was added in fiscal year 2022 with an ending balance of \$127,982.

OPEB- Has been reduced from \$4,134,100 to **\$1,443,076** a total of \$2,691,024.

Un-Restricted:

Operating Reserve (Cash Flow) – Has been increased from \$2,046,856 to **\$4,408,985** a total of \$2,362,129.

Storm Damage - Has been reduced from \$2,656,009 to **\$2,346,282** a total of \$309,727.

Variation in Water Sales - Has been increased from \$2,604,460 to **\$3,544,353** a total of \$939,893.

Capital Replacement - Has had no change and remains at **\$1,985,040**.

Conservation Penalty – Has been increased from \$3,933,598 to **\$4,577,607** a total of \$644,009.

Alternate Water Supply – Has been decreased from \$1,970,930 to **\$1,107,797** a total of

\$863,133.

The net change - The net change for Reserves from Fiscal Year End 2020 / 2021 to Fiscal Year End 2021 / 2022 is \$2,784,852.

Staff recommends that the Board of Directors sets the District's Fiscal Year 2022/2023 reserve account amounts as listed above.

**Casitas Municipal Water District
Reserves / Restricted – Unrestricted
FY 2021/2022**

6/30/2022

| | |
|---|----------------------|
| General Balance - Mechanics Bank | 7,389,328 |
| Adjudication Balance- Mechanics Bank | 127,982 |
| OPEB 115 Trust | 1,443,076 |
| LAIF | 483 |
| U.S. Bank Custodial Account | 9,912,550 |
| U.S. Bank Money Market Account | 986,964 |
| County of Ventura Investment (C.O.V.I.) | 3,066 |
| CFD 2013-1 Improvement Fund | 6,819,665 |
| Total Reserves | 26,683,113.74 |

| | |
|---|-------------------|
| Restricted: | |
| Capital Facilities | 322,327 |
| CFD 2013-1 Improvement Fund | 6,819,665 |
| Adjudication Fund | 127,982 |
| OPEB | 1,443,076 |
| Total Restricted | 8,713,050 |
| Un-Restricted (designated funds) | |
| Operating Reserve | 4,408,985 |
| Storm Damage | 2,346,282 |
| Variation in Water Sales | 3,544,353 |
| Capital Replacement | 1,985,040 |
| Conservation Penalty | 4,577,607 |
| Alternate Water Supply | 1,107,797 |
| Total Un-Restricted (designated funds) | 17,970,064 |
| Un-designated funds 06/30/2022 | - |
| Total Un-Restricted | 17,970,064 |
| Total Reserves | 26,683,114 |
| | - |

Restricted funds = Funds restricted by a third party and/or for Debt Service Fund.
Designated funds = Funds designated by Board for specific purpose.

CASITAS MUNICIPAL WATER DISTRICT
MEMORANDUM

| | |
|----------|--|
| TO: | BOARD OF DIRECTORS |
| FROM: | MICHAEL FLOOD, GENERAL MANAGER |
| SUBJECT: | DECLARATION OF SURPLUS DISTRICT PROPERTY |
| DATE: | 10/21/22 |

RECOMMENDATION:

It is recommended that the following District be declared surplus and staff be directed to dispose of same:

Vehicles:

- Unit #19 - 2003 Chevy ¾ Ton Utility – Enterprise
- Unit #35 – 2001 Chevy ½ Ton - Enterprise
- Unit #80 – 2000 Ford 1-Ton Welding - Enterprise

Out of service equipment:

- Administration Metal Safe - GovDeals

BACKGROUND:

The vehicles and equipment that are recommended to sell have exceeded their useful life and are now either inoperable or been replaced by newer units.

Equipment on Unit #80 has been moved to other vehicles and it’s ready to be removed from the fleet.

The following is an estimate on expected revenue generated from the vehicle sale:

Table 1 – Estimated Revenue

| Unit # | Unit Description | Enterprise Fee | Est. Low Value | Est. High Value |
|--------|-------------------------|----------------|----------------|-----------------|
| 19 | 1997 Ford ¾ Ton Utility | \$400 | \$400 | \$1,400 |
| 35 | 2001 Chevy ½ Ton PU | \$400 | \$1,800 | \$2,800 |
| 80 | 2000 Ford 1 Ton | \$400 | \$500 | \$1,500 |

FINANCIAL IMPACT:

It is estimated to generate \$2,700 - \$5,700 in revenue to the 2022/23 budget with a cost of goods sold of \$1,200.

**CASITAS MUNICIPAL WATER DISTRICT
MEMORANDUM**

TO: BOARD OF DIRECTORS
FROM: MICHAEL L. FLOOD, GENERAL MANAGER
SUBJECT: APPROVE AN UNBUDGETED ITEM IN THE AMOUNT OF \$48,000 AND AWARD A CONTRACT TO C&W DIVING TO PERFORM CASITAS DAM INTAKE STRUCTURE ANODES REPLACEMENT IN THE NOT-TO-EXCEED AMOUNT OF \$34,000.92.
DATE: 10/21/2022

RECOMMENDATIONS:

- Approve an Unbudgeted Item in the amount of \$48,000.00 for Fiscal Year 2022-2023.
- Authorize the General Manager to sign a Purchase Order Contract to the lowest responsible bidder, C&W Diving in an amount not to exceed \$34,000.92.

BACKGROUND:

The District estimates 70 sacrificial anodes are installed on the existing Casitas dam intake structure which provides protection to prevent corrosion of critical facilities to maintain water supply from Lake Casitas.

The anodes were originally installed at the facility in 1965 and require replacement due to the useful life of each anode nearing its end. District staff has replaced all anodes above the water line which totals 25. To take advantage of the low water level the District recommends replacing as many of the anodes as possible without requiring substantial dive equipment due to extensive safety dive requirements. Of the 45 anodes that remain below the water line, approximately 27 are expected to be replaced to reach a depth permitted by standard dive requirements.

Three prices were solicited and two bids were received as shown in Table 1.

Table 1 – Bid Summary

| Bidder | Total Bid |
|----------------------------|------------------|
| C&W Diving | \$34,000.92 |
| J.F. Brennan Company, Inc. | \$73,092.00 |
| Aqueous Corporation | No Bid |

Casitas will purchase the anodes plus other materials separately thus material costs are estimated amount at \$7,000. The attachment hardware will need to be machined which is estimated to cost another \$7,000. Staff requests a total unbudgeted item approval of \$48,000 for the 2022-2023 Fiscal Year for this project.

FINANCIAL IMPACT: An unbudgeted item approval of \$48,000.00 is requested for the current fiscal year will be withdrawn from capital reserves, if necessary.

Attachments: Contractor proposals

THE INFORMATION CONTAINED IN THIS DRAWING IS THE SOLE PROPERTY OF GALVOTEC ALLOYS, INC.. ANY REPRODUCTION IN PART OR WHOLE WITHOUT THE WRITTEN PERMISSION OF GALVOTEC ALLOYS, INC.. IS PROHIBITED.

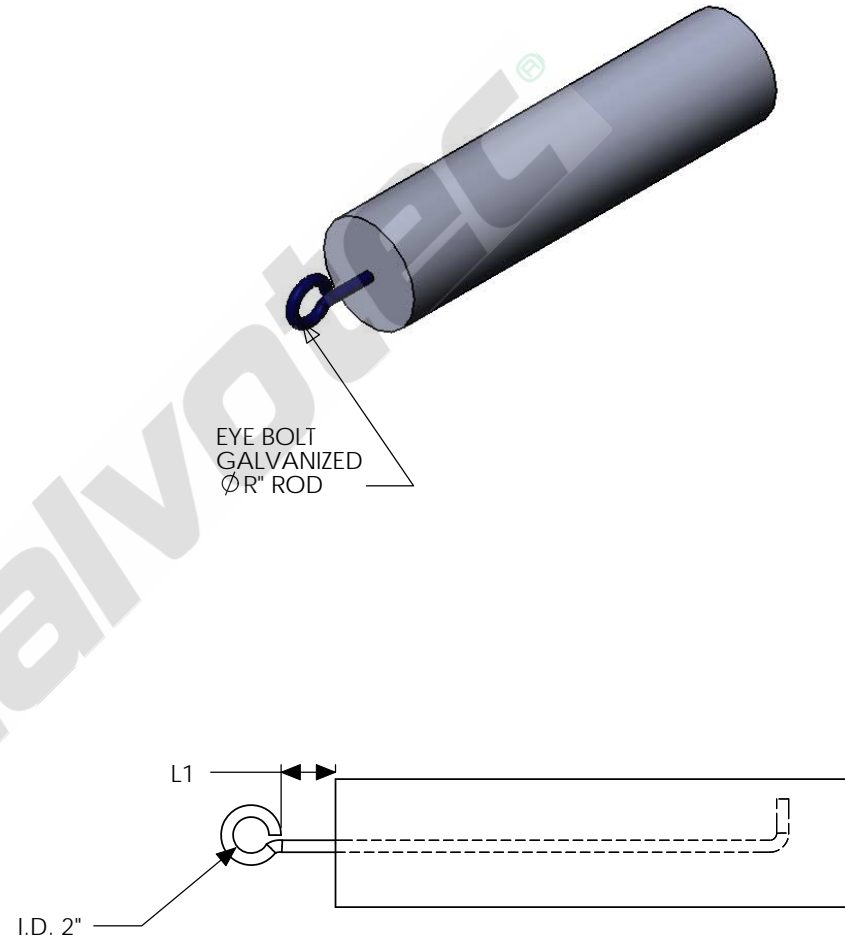
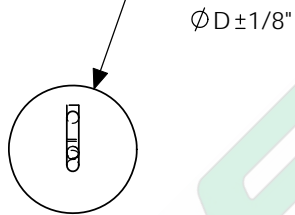
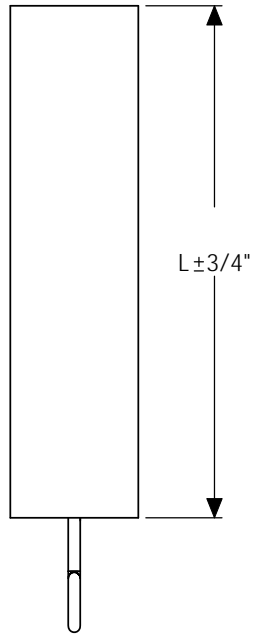

| | L (in) | L1 (in) | D (in) | R (in) | (lbs) Of Mag | (lbs) of core | TOTAL (lbs) |
|----------------|--------|---------|--------|--------|--------------|---------------|-------------|
| GA-MG-P-50C | 16 | 3 | 8 | 1/2 | 48.5 | 1.5 | 50 |
| GA-MG-P-100C | 32 | 3 | 8 | 1/2 | 96 | 2 | 100 |
| GA-MG-P-100C-1 | 32 | 3 | 8 | 3/4 | 98 | 5 | 103 |
| GA-MG-P-200C | 27 | 3 | 12 | 3/4 | 191 | 5 | 196 |

| | |
|-------------|---------|
| NEXT ASSY | USED ON |
| APPLICATION | |

UNLESS OTHERWISE SPECIFIED DIMENSIONS ARE IN INCHES TOLERANCES ARE:
NOT CRITICAL

MATERIAL --

FINISH --

DO NOT SCALE DRAWING

CAD GENERATED DRAWING, DO NOT MANUALLY UPDATE

| | |
|-------------|----------|
| APPROVALS | DATE |
| DRAWN L. H. | 11/15/01 |
| CHECKED | |
| RESP ENG | |
| MFG ENG | |
| QUAL ENG | |

MAGNESIUM ALLOY PIER ANODE

REV. 2 REV. Date: 02/27/13

SIZE A DWG. NO. GA-MG-P-XXXX

SCALE CAD FILE: GA-MG-P-XXXX SHEET OF



2022

J.F. BRENNAN COMPANY, INC.

Lake Casitas Anode Replacement
Casitas Municipal Water District
Oak View, CA

10/5/2022

Revision X

Information herein is released solely to Casitas Municipal Water District and their designated engineering firm.
Release to any third party is not permitted without consent from J.F. Brennan Company, Inc.

Wednesday, October 5, 2022

Virgil Clary
Casitas Municipal Water District
1055 N. Ventura Ave
Oak View, CA 93022
805-649-2251
vclary@casitaswater.com

Re: Lake Casitas Anode Replacement

Virgil Clary,

J.F. Brennan Company, Inc. (Brennan) is pleased to provide the enclosed proposal for your Lake Casitas Anode Replacement project. Our entire organization, team of engineers, and construction professionals are all grateful for the opportunity to submit this plan describing how the work can proceed in the safest, highest quality, and most efficient manner possible.

Thank you for the opportunity to submit our proposal for the Lake Casitas Anode Replacement project. Our team is prepared to answer questions you may have regarding the pricing or proposal. Please do not hesitate to contact us at your earliest convenience.

Sincerely,

Merril Collins

Regional Dive Manager - Western Region
J.F. Brennan Company, Inc.
mcollins@jfbrennan.com
707-759-0243



Table of Contents

Information herein is released solely to Casitas Municipal Water District and their designated engineering firm. Release to any third party is not permitted without consent from J.F. Brennan Company, Inc.

- 1 COMPANY OVERVIEW4**
- 2 PROJECT OVERVIEW5**
- 3 SCOPE OF WORK5**
 - 3.1 Optional Bid Item 1: Mobilization/Demobilization (\leq (-)99 FFW and Dive Vessel)..... 5
 - 3.1.1 Includes the Following: 5
 - 3.1.2 Excludes the following: 5
 - 3.2 Optional Bid Item 2: Mobilization/Demobilization (\geq (-)100 FFW and Small Sectional Barge and Dive Support Vessel)..... 6
 - 3.2.1 Includes the Following: 6
 - 3.2.2 Delays caused by others Excludes the following: 6
 - 3.3 Optional Bid Item 1A: Installation of Anodes on Intake Structure (Waterline to (-)99 FFW) 6
 - 3.3.1 Includes the Following: 6
 - 3.3.2 Delays caused by others Excludes the following: 6
 - 3.4 Optional Bid Item 2A: Installation of Anodes on Intake Structure (Waterline to (-)160 FFW) 6
 - 3.4.1 Includes the Following: 6
 - 3.4.2 Delays caused by others Excludes the following: 6
- 4 FEE ESTIMATE.....7**
- 5 ASSUMPTIONS7**



1 COMPANY OVERVIEW

J.F. Brennan Company, Inc. (Brennan) is a marine construction and environmental remediation firm specializing in dam construction and repair projects located throughout the waters of the United States. In our over 100 years of conducting business, Brennan has accumulated and assembled a substantial workforce of talented individuals with our core focus centralizing in working in the marine environment. Along with our



collection of highly skilled union labor, Brennan has strived at becoming the foremost leader in developing innovative solutions for our clients on challenging marine construction projects. Additionally, Brennan has become an industry leader when it comes to education and safety of our highly skilled labor professionals. This innovative culture produces an unmatched pool of talented individuals to draw from, whether we're working on a highly complex multimillion dollar environmental restoration project, or the simple one-day dive inspection. Either instance, Brennan approaches every project equally, however large, or small, and provides the same level and attention to detail with forethought and innovation to accomplish the project safely, and ahead of schedule. Through the years, our clientele has continually grown and ranged from differing utility companies who operate a variety of dam structures, paper mills, municipalities to differing government agencies such as the USACE, BOR, BIA, US Navy, and most major ports and districts throughout the United States. The following proposal outlines the services in which J.F. Brennan Company (JFB) can provide to Casitas Municipal Water District . All Brennan diving operations are conducted in accordance with Brennan's Safe Diving Practices Manual as well as all pertinent ADCI, OSHA, and USCG regulations (whichever is the most stringent). All members of the dive team are currently and will continue to be up to date on all pertinent certifications required to safely complete the services outlined within the project scope.



2 PROJECT OVERVIEW

| | | | |
|-----------------------|----------------------------------|--------------------------|----------------|
| Customer: | Casitas Municipal Water District | Start Date: | TBD |
| Location: | Oak View, CA | Completion Date: | November, 2022 |
| Work Schedule: | 10 Hr. Shifts (M-F) | Shift Start Time: | 0630 |

Project Location



3 SCOPE OF WORK

3.1 Optional Bid Item 1: Mobilization/Demobilization (≤ (-)99 FFW and Dive Vessel)

3.1.1 Includes the Following:

- 3.1.1.1 Diving and Safety Submittals
- 3.1.1.2 Mobilization of labor, equipment, materials, and safety gear:
 - 5-man ADCI certified dive team
 - Surface supplied shallow air dive system
 - U/W HD video system
 - 28' Dive support vessel
 - Quagga mussel quarantine/inspection of equipment

3.1.2 Excludes the following:

- 3.1.2.1 Delays caused by others

3.2 Optional Bid Item 2: Mobilization/Demobilization (≥ (-)100 FFW and Small Sectional Barge and Dive Support Vessel)

3.2.1 Includes the Following:

- 3.2.1.1 Diving and Safety Submittals
- 3.2.1.2 Mobilization of labor, equipment, materials, and safety gear:
 - 5-man ADCI certified dive team
 - Surface supplied deep air dive system
 - Deck decompression chamber (to allow for longer bottom times)
 - U/W HD video system
 - 28' Dive support vessel
 - 30' x 30' sectional barge
 - Quagga mussel quarantine/inspection of equipment
- 3.2.1.3 All permanent materials

3.2.2 Delays caused by others Excludes the following:

- 3.2.2.1 Delays caused by others

3.3 Optional Bid Item 1A: Installation of Anodes on Intake Structure (Waterline to (-)99 FFW)

3.3.1 Includes the Following:

- 3.3.1.1 Dive team to install district furnished anodes on intake structure from waterline to 99 FFW
- 3.3.1.2 Video inspection report following completion

3.3.2 Delays caused by others Excludes the following:

- 3.3.2.1 Anodes and hardware
- 3.3.2.2 Delays caused by others

3.4 Optional Bid Item 2A: Installation of Anodes on Intake Structure (Waterline to (-)160 FFW)

3.4.1 Includes the Following:

- 3.4.1.1 Dive team to install district furnished anodes on intake structure from waterline up to 160 FFW
- 3.4.1.2 Video inspection report following completion

3.4.2 Delays caused by others Excludes the following:

- 3.4.2.1 Anodes and hardware
- 3.4.2.2 Delays caused by others

4 FEE ESTIMATE

| J. F. BRENNAN - PRICING SUMMARY | | | | | |
|---------------------------------|--|---------------|-------|-----|---------------|
| Bid Item | Description | Unit Price | Units | UOM | Subtotal |
| Opt. 1 | Mobilization/Demobilization (≤ 99 FFW) Utilizing JFB Dive Vessel and District Barge | \$ 1,276.00 | 1 | LS | \$ 1,276.00 |
| OPT. 2 | Mobilization/Demobilization (≥ 100 FFW) Utilizing JFB Provided Barge and JFB Vessel | \$ 59,835.00 | 1 | LS | \$ 59,835.00 |
| OPT 1A | Installation of 50 lb. Anodes (≤ 99 FFW to Waterline) JFB Provided Vessel & District Barge | \$ 71,816.00 | 1 | LS | \$ 71,816.00 |
| OPT 2A | Installation of Anodes from (-) 160 FFW to Waterline (JFB Provided Barge and Vessel) | \$ 128,697.00 | 1 | LS | \$ 128,697.00 |

5 ASSUMPTIONS

- Excludes engineering and environmental controls including permitting, turbidity monitoring, water quality BMPs, onsite biologist, etc.
- Third party costs (if any) will be charged at cost plus 15%, unless mentioned above.
- Casitas Municipal Water District will provide transport of anodes to the boat launch.
- Reasonable site access.
- Workdays will be paid out in full once onsite; no partial days are assumed.
- No permits, licenses, or fees of any kind.
- No off-site training required. Onsite site-specific training <30 minutes.
- Water diversion and LOTO will be <30 minutes of downtime.
- No weekend mobilization.

General Notes:

This proposal does not consider additional costs for mobilization nor account for scheduling conflicts that may arise due to COVID-19. Brennan reserves the right to charge the customer for any costs related to COVID-19 and will not be subject to any penalties for COVID-19 scheduling conflicts.

Any repairs or modifications considered based on Brennan's inspection reports are recommendations only and based upon constructability and our knowledge of successful repairs previously performed in similar circumstances. These recommendations should be reviewed by a qualified individual for concurrence, to verify the recommended method will perform effectively, and to finalize the design details within appropriate codes and regulations. It is assumed that a contract with mutually agreeable terms and conditions will be arrived at. This proposal is valid for 30 days.





C&W Diving Services, Inc.

3561 Dalbergia St.
 San Diego, CA 92113
 (619) 474-2700 Office

QUOTE

| DATE | QUOTE # |
|-----------|---------|
| 9/30/2022 | 22-121 |

| PREPARED BY |
|-------------|
| Mark Graham |

| NAME/ADDRESS | |
|--|--------------|
| Casitas Municipal Water District 1055 N. Ventura Avenue Oak View, CA 93022 | |
| CONTACT | PHONE |
| Virgil Clary | 805-535-8034 |

| LOCATION OF WORK |
|---|
| Casitas Dam Entrance Gates 3 to 6 |

| PERIOD OF PERFORMANCE | WORK ITEM | | TERMS |
|--|----------------------|----------|-----------|
| 10/2022-11/2022 | Anode Replacement | | Net 30 |
| DESCRIPTION | QTY | Rate | TOTAL |
| C&W Diving Services is providing Prevailing wage pricing for a 5-man 3-wet dive crew to replace (27) 50 pound clamp on anodes from elevation 398 gate/screen 3 (80' FFW) to water line gate/screen 6. | | | |
| 5-man dive crew 4-wet, prevailing wage 8-hour (minimum) days to install (27) 50 pound clamp on anodes from gate 3 (80' FFW) to gate 6 (water line) at reservoirs current water level of 484' above sea level | 3 Days | 9,833.00 | 29,499.00 |
| Crane rental to load and off load all dive equipment onto Casitas MWD 24' x 14' barge | 2 Trips to reservoir | 3,000.00 | |
| Per Deim & lodging for dive crew for 4 nights | 4 Nights | 562.98 | 2,251.92 |
| Mobilization & Demobilization of shallow water dive spread, equipment and personnel, fuel sure charge included from shop location to Casitas Dam and back | 1 | 2,250.00 | 2,250.00 |
| Notes: 1) Quote 22-121 is for a 5-man 4-wet dive crew, 8-hour minimum prevailing wage pricing to install (27) Anodes from gate 3 to gate 6 | | | |
| TOTAL | | | |

1) This estimate does not include the cost of materials (unless specified above) or delays caused by others and is subject to availability of personnel and equipment at time of award.

2) All diving will be accomplished IAW OSHA CFR 29 1910 Subpart "T" and ADCI Consensus Standards.

C&W maintains an ABS External Specialist Certificate for In Water Survey (UWILD) and is Lloyd's Registered

C&W is a Small Disabled Veteran-Owned Business
 Contractors License # A-389407 / Cage Code 3U320
www.cwdiving.com



C&W Diving Services, Inc.

3561 Dalbergia St.
 San Diego, CA 92113
 (619) 474-2700 Office

QUOTE

| DATE | QUOTE # |
|-----------|---------|
| 9/30/2022 | 22-121 |

| PREPARED BY |
|-------------|
| Mark Graham |

| NAME/ADDRESS | |
|--|--------------|
| Casitas Municipal Water District 1055 N. Ventura Avenue Oak View, CA 93022 | |
| CONTACT | PHONE |
| Virgil Clary | 805-535-8034 |

| LOCATION OF WORK |
|---|
| Casitas Dam Entrance Gates 3 to 6 |

| PERIOD OF PERFORMANCE | WORK ITEM | | TERMS |
|--|-------------------|------|--------------------|
| 10/2022-11/2022 | Anode Replacement | | Net 30 |
| DESCRIPTION | QTY | Rate | TOTAL |
| 2) Due to OSHA and ADCI guidelines, divers will only be able to install anodes up to 80' FFW depth. All anodes that will be required to be install that are past 80' FFW depth will require a decompression chamber on site. Separate pricing will be provide to install the remaining (18) 50 pound anodes from gate 3 to gate 1 3) Due to reservoir 35 day vessel quarantine process, C&W will be loading all dive equipment onto Casitas MWD 24' x 14' barge and conduct all dive operations from the barge 4) A separate line item has been provided for the option of a crane to load the dive equipment onto the barge 5) All 50 pound anodes and clamps will be required to be fully assembled and read for installation upon arrival for the work. 6) Quote 22-121 pricing is to leave the existing anodes and clamps in place and install all new anodes. If old anodes are required to be removed and recovered, additional days will be required 7) PO will need to be provided to C&W prior to mobilizing to project location | | | |
| TOTAL | | | \$34,000.92 |

1) This estimate does not include the cost of materials (unless specified above) or delays caused by others and is subject to availability of personnel and equipment at time of award.

2) All diving will be accomplished IAW OSHA CFR 29 1910 Subpart "T" and ADCI Consensus Standards.

C&W maintains an ABS External Specialist Certificate for In Water Survey (UWILD) and is Lloyd's Registered

C&W is a Small Disabled Veteran-Owned Business
 Contractors License # A-389407 / Cage Code 3U320
www.cwdiving.com

**CASITAS MUNICIPAL WATER DISTRICT
MEMORANDUM**

TO: BOARD OF DIRECTORS
FROM: MICHAEL FLOOD, GENERAL MANAGER
SUBJECT: CAMP CHAFFEE PUMP STATION UPDATE
DATE: 10/26/2022

RECOMMENDATION:

- Approve a budget of \$60,000 for the Camp Chaffee Pump Station
- Authorize the General Manager to issue a Task Order to Cannon Corporation for Camp Chaffee Pump Station design services in an amount not to exceed \$39,250.00

BACKGROUND AND DISCUSSION:

Casitas Municipal Water District (District) has a small service area in the Camp Chaffee community in Foster Park. The water system relies on the level in Lake Casitas to maintain pressure in the service zone. With the lake level dropping, service pressure to the Camp Chaffee system will drop too low to be fed by gravity. A preliminary design report was completed in 2019 which recommended installation of a skid-mounted booster pump to serve the community when pressures are below the required minimum of twenty pounds per square inch (psi).

The District received a proposal from Cannon Corporation (Cannon) to provide services to update the preliminary construction cost estimate, and provide complete design services which includes survey, design plans and specifications, and assistance with Southern California Edison (SCE) and Ventura County. Their proposal includes these services in an amount not to exceed \$39,250.

BUDGET IMPACT:

The budget for fiscal year 2022-23 did not include a line item for the project. The proposed services cost \$39,250. A contingency is included to cover SCE fees and assistance with easement acquisition.

**Table 1 – Camp Chaffee Pump Station Design Update
Cost Estimate**

| Description | Estimated Cost |
|---------------------|-----------------|
| Engineering Support | \$40,000 |
| Contingency (25%) | \$20,000 |
| Total | \$60,000 |

Attachment: Cannon proposal dated September 13, 2022



September 13, 2022

Lindsay Cao, PE
Sr. Project Manager
Casitas Municipal Water District
1055 N. Ventura Avenue
Oak View, CA 93022

PROJECT: CAMP CHAFFEE AND FOSTER PARK PUMP STATION PROPOSAL

PROJECT UNDERSTANDING

Casitas Municipal Water District (District) has a small service area in the Camp Chaffee area that relies on lake levels to maintain pressure in their service zone. With lake levels dropping, service pressures to the Camp Chaffee area will drop too low to run on a gravity feed system. The District would like to install a skid mounted booster pump to serve the community when pressures are below the required pressure, as well as provide fire flows to the community. A preliminary design report has been completed, and the District would like to construct the facility. Electrical service to run the pump will need to be installed. A temporary generator can run the pump until service is established. The pump station will be located on an easement within Ventura County Parks property.

Approach and Scope of Services

To successfully complete this project, our approach is based on providing professional services as described in the following tasks:

- **Task 1** Preliminary Engineering
 - Site Visit and Kickoff Meeting
 - Cost Estimates
 - Design and Construction Schedule
 - Edison Coordination
 - Pump Re-sizing Summary Memo
- **Task 2** Survey
- **Task 3** Design Plans
- **Task 4** County Property Acquisition Coordination and Exhibits

Task 1 Preliminary Engineering

- We will begin this project with a kick-off meeting/site visit with District staff to steer and further clarify critical elements of the project and locate existing facilities. This will help verify site constraints and design needs.
- We will prepare preliminary cost estimates for the construction cost of the facility, including piping connections, skid mounted pump station costs, and overall site

construction. Southern California Edison (SCE) fees and County property easement costs shall be supplied by others but will be included if they are able to be obtained. (We will reach out to SCE and Hamner Jewell & Associates to inquire).

- A preliminary design and construction schedule will be prepared that will outline the overall estimated duration of the project. We will coordinate with the skid-mounted pump station vendor to estimate anticipated lead times for the equipment, with SCE for meter pedestal and transformer lead times, and with the County and Hamner Jewell for easement acquisition timelines.
- Once a preliminary site layout and load determination has been made, we will assist in coordination efforts with SCE for securing power to the proposed site. The District will be the lead, but our team will help prepare the application and exhibits needed for the District to submit the application for power. We will help with coordination efforts throughout the design process to ensure they have the information they need to supply power to the facility.
- The original intent of the project was to replace all the water mains in the Camp Chaffee / Foster Park area to improve fire flow, however due to dropping lake levels, the pump station needs to be installed immediately. We will update the pump sizing calculations based on the existing 4-inch and 6-inch water mains in the development and prepare a summary memo with the new design parameters.

Task 2 Survey

The area where the new skid-mounted pump station will be located is on County owned property. While we have obtained general topographical information for the Foster Park development, there is no available information for the new pump station site. Our survey crew will perform a ground survey of the County park property and roadway to obtain surface features of the work area, recover the boundary, process the topo, and prepare a base map for site layout and design. Survey will include gathering information on existing corridor features, including edges of pavement, fences, utility poles, driveways, drainage swales, nearby above ground structures, above ground cable, electrical boxes, fire hydrants located within or adjacent to the project, water system appurtenances, sanitary sewers and storm drain manholes, catch basins and inlets with inlet and invert elevations, and locations of trees that are four inches in diameter or greater within or adjacent to the project work areas.

Task 3 Design Plans

We will prepare and submit design plans for the project so it can be bid on and constructed in a timely manner. The design plan will provide a location map and site plan/layout of equipment and electrical components with sufficient information to construct the facility. The plan will be utilized to submit to SCE for installation of a meter pedestal. Details of the piping connections, pumps, electrical equipment, and hydropneumatic pressure tank will be included. We will obtain pertinent operations and record drawing information needed for design and prepare a preliminary layout plan and an outlined materials list for the equipment needed to complete the booster pump station installation. Coordination with the skid-mounted pump station supplier will be provided, as well as coordination on locating the site within County Parks Department property. Design deliverables for plans will be provided at the following:



- 60% Design Plans
- 90% Design Plans and Specs
- Final Design Plans and Specs

Task 4 County Property Acquisition Coordination and Exhibits

The pump station location is slated to be on County Parks property at the intersection of Camp Chaffee Road and Casitas Vista Road. The District will need to obtain an easement for the property needed for the pump station site. It is our understanding that preliminary investigations have been completed to obtain this property. In order to finalize easements for the pump station, certain exhibits will need to be completed. Our survey team will help with coordination and assist the District and Hamner Jewell in preparing the necessary easement document exhibits required for this acquisition. These will consist of a legal description and plat.

SCHEDULE

The final bid package will be delivered as quickly as possible so the SCE application can be submitted, and the project can be bid and pump equipment can be ordered as soon as possible. A preliminary layout can be prepared and submitted for review 1-2 weeks after survey is completed.

EXCLUSIONS

The following exclusions apply to this proposal, but can be added at the request of District:

- Geotechnical Investigations
- Potholing

FEES (INCLUDES REIMBURSABLES)

Camp Chaffee and Foster Park Pump Station

| | | |
|----------------|--|------------------------|
| <i>Task 1.</i> | <i>Preliminary Engineering</i> | <i>\$ 8,500</i> |
| <i>Task 2.</i> | <i>Survey</i> | <i>\$5,750</i> |
| <i>Task 3.</i> | <i>Design Plans</i> | |
| | • <i>Civil Design</i> | <i>\$10,500</i> |
| | • <i>Electrical Design</i> | <i>\$6,500</i> |
| <i>Task 4.</i> | <i>County Property Acquisition Coordination and Exhibits</i> | |
| | • <i>Coordination</i> | <i>\$3,500</i> |
| | • <i>Easement Exhibits</i> | <i>\$4,500</i> |
| Total: | | <u>\$39,250</u> |

The Cannon Corporation Agreement for On-Call Engineering Services FY 22-23 outlines the terms for work. Cannon bills monthly for work in progress and payment is due within 10 calendar days of receipt of the bill. In witness whereof, the parties hereto have caused this



agreement to be executed and effective as of the date and year first above written. Any additions and/or corrections to this agreement will be addressed in a separate agreement.

Casitas Municipal Water District _____

Cannon _____

X _____ Date _____
Name

X _____ Date _____
Larry Kraemer, PE
Director – Public Infrastructure

Title

**CASITAS MUNICIPAL WATER DISTRICT
MEMORANDUM**

TO: BOARD OF DIRECTORS
FROM: MICHAEL FLOOD, GENERAL MANAGER
SUBJECT: HYDROLOGIC STATUS REPORT FOR SEPTEMBER 2022
DATE: OCTOBER 26, 2022

RECOMMENDATION:

This item is presented for information only and no action is required. Data are provisional and subject to revision.

DISCUSSION:

Rainfall Data

| | Casitas Dam | Matilija Dam | Thacher School |
|----------------------------------|-------------|--------------|----------------|
| This Month | 0.04" | 0.17" | 0.22" |
| Water Year (WY: Oct 01 – Sep 30) | 17.78" | 22.22" | 16.15" |
| Average station rainfall to date | 23.31" | 28.23" | 21.53" |

Ojai Water System Data

| | |
|--|-------------|
| Wellfield production | 119.10 AF |
| Surface water supplement | 57.52 AF |
| Static depth to water surface – Mutual #6 | 170.82 feet |
| Change in static level from previous month | - 9.41 feet |

Robles Fish Passage and Diversion Facility Diversion Data

| | |
|-----------------------------|----------|
| Diversions this month | 0 AF |
| Diversion days this month | 0 |
| Total Diversions WY to date | 2,521 AF |
| Diversion days this WY | 27 |

Casitas Reservoir Data

| | |
|---|------------------|
| Water surface elevation as of end of month | 481.65 feet AMSL |
| Water storage last month | 74,630 AF |
| Water storage as of end of month | 72,973 AF |
| Net change in storage | - 1,657 AF |
| Change in storage from same month last year | - 6,757 AF |

AF = Acre-feet

AMSL = Above mean sea level

WY = Water year

CASITAS MUNICIPAL WATER DISTRICT
MINUTES
Recreation Committee
(this meeting was held telephonically and in-person)

DATE: October 21, 2022
TO: Board of Directors
FROM: General Manager, Michael Flood
Re: Recreation Committee Meeting of October 11, 2022, at 1000 hours.

RECOMMENDATION:

It is recommended that the Board of Directors receive and file this report.

BACKGROUND AND OVERVIEW:

1. **Roll Call.**

- Director Brian Brennan
- Director Pete Kaiser
- General Manager, Michael Flood
- Park Services Manager, Joe Martinez
- Division Officer, Joe Evans

2. **Public Comments.**

None

3. **Discussion of reduced fees related to the Casitas Rowing Club members**

GM Flood covered the contents of the memo with the Committee

Director Brennan indicated that the Frequent Visitor Decal (FVD) was an adequate mechanism for those that visit the lake on a regular basis can receive a discounted entry cost.

Director Kaiser indicated that the FVD was adequate and that the LCRA needs no maintain its revenues and a special discount program would be difficult to manage.

The Committee directed staff to record the Committee's opinion in the minutes in order to inform the Board that no further consideration of the request is recommended.

4. **Review of August 2022 Recreation Report**

PSM Martinez went over the report with the Committee including attendance, revenues, various events, vessel tagging, campsite renovations, Casitas Water Adventure staffing and attendance, and maintenance activities.

Director Brennan made comments regarding the staffing issues, future recruitment of lifeguards, an opening date for the new Aquatic Play Structure, and thanked staff for the great job being done.

Director Kaiser made comments regarding the great job LCRA staff is doing and the training of lifeguards/recruitment.

The Committee asked that a future item be brought to the Committee regarding paying lifeguard recruits for training.

5. **Review of Incidents and Comments**

DO Evans went over the month's statistics including workload indicators, calls for service, patrol observations, violations, a 911 hang-up call, and a traffic collision.

DO Evans also mentioned that he is working with County staff to have 'No Parking' signs placed on the northern section of Santa Ana Road in the watershed. This will help curtail issues of overnight camping and dumping activities.

Director Kaiser commended staff's efforts.

Director Brennan complimented staff, expressed appreciation for the detailed report and indicated that the County had implemented 'No Parking' signage in other areas where overnight camping and dumping was an issue and that it had worked well.



**VENTURA
RIVER
WATER
DISTRICT**

409 Old Baldwin Road
Ojai, CA 93023
Phone (805) 646-3403
VenturaRiverWD.com

DIRECTORS

- ❖ Peggy Wiles, President
- ❖ Nathan Rosser, Vice President
- ❖ Ed Lee, Treasurer
- ❖ Bruce Kuebler, Director
- ❖ Jack Curtis, Director

GENERAL MANAGER

Bert Rapp, P.E.
Bert@VenturaRiverWD.com

**ASST. GENERAL
MANAGER**

Alma Quezada, P.G.
Alma@VenturaRiverWD.com

OFFICE MANAGER

Emily Arnbrister
Emily@VenturaRiverWD.com

FIELD SUPERVISOR

Mark Albertsen
Mark@VenturaRiverWD.com

ATTORNEY

Lindsay Nielson, ESQ
NielsonLaw@aol.com

Casitas Board of Directors
Casitas Municipal Water District
1055 Ventura Ave.
Oak View, CA 93022

SUBJECT: RECOMMENDATION TO IMPLEMENT STAGE 4 DROUGHT FORTHWITH

Dear Directors of the Casitas Municipal Water District,

Lake Casitas' water level is expected to drop to the Stage 4 Drought trigger point in the next few weeks for the first time in its 64-year history. This coincides with one of the State's most severe drought periods at the onset of what is expected to be another less than average rainy season.

This creates a difficult decision for the Casitas Board because no one knows how much rain we might receive this year and it can be confusing for customers to move back and forth between drought stages. But the impact of imposing Stage 4 in June and then possibly Stage 5 in August would be worse in our opinion.

A look back at historical trends have proven to be a good indicator of what to expect in the coming months. In the fall of 2018, the National Weather Service (NWS) forecast an "equal chance of normal rain" in the winter of 2019 (Figure 1).

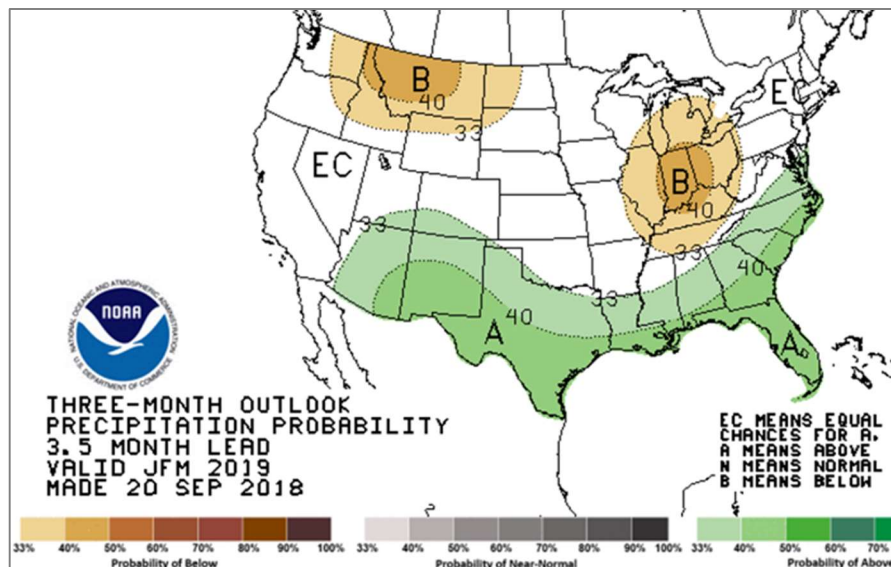

Figure 1: National Weather Service Forecast for 2019 Winter.

The prediction came to fruition: in January 2019 the lake level dropped to a record low of 30.4% then later in January, February, and March it rained 21 inches and lake level rose to 45%. The Casitas Board elected to stay at Stage 3 and it worked out well.

However, this fall, the NWS has forecast a third consecutive La Niña event with a strong “below normal” chance of rain predicted this winter but with a wetter fall, similar to last year (Figure 2).

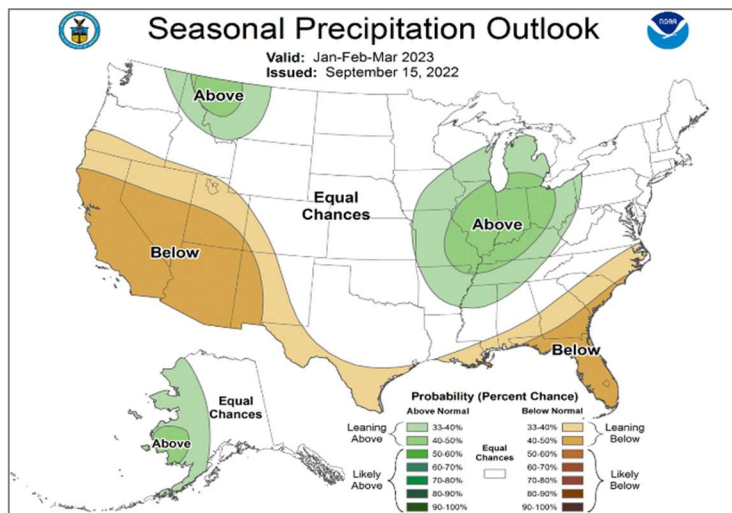

Figure 2: National Weather Service Seasonal Precipitation Outlook Winter 2023

Also see NOAA’s success rate over the last five years in Figure 3 below. It shows that NOAA’s ability to estimate the future magnitude of a rain year is improving.

Casitas MWD projects the lake will provide sufficient water for another 3 to 4 years if no significant rain is received, and current water demands remain constant. Lake Casitas was designed for a 21-year drought design life, but we may need more than the 21-year life.

The VRWD Board and the Casitas Board are concerned about providing adequate fire protection in our service areas where water pressure is dependent on the depth of water in the lake. Each of our agencies are in the process of purchasing booster pumps to maintain adequate fire flows from fire hydrants as the lake drops. These booster pumps cannot be installed for about a year because they must be designed, manufactured and installed. Reducing water usage will help maintain the depth of the lake and fire flows in the areas served by gravity flow from the lake until the booster pumps can be installed.

The Board of Directors of the Ventura River Water District recommend that Casitas implement Stage 4 at this time rather than postponing until the Spring of 2023. We would like to note that although it is commendable that customers have exceeded conservation efforts beyond the Stage 3 requirements, additional conservation efforts are still needed to prolong the lake’s water supply.

There is a strong probability that if Stage 4 is postponed until May or June, higher water demands would continue for another 6 months, and we could be faced with a Stage 5 Drought declaration as early as August. This would provide little time for customers to adjust to Stage 4 water restrictions before being thrust into Stage 5. Implementing a Stage 4 Drought Declaration now will encourage customers to adapt to increased conservation efforts and encourage converting landscapes to low-water plants, implement rainwater capture systems and greywater reuse. Winter is the best time to get replacement plants established compared to waiting for May or June.

Recommendation for Stage 4 Drought
Page 3 of 3

With regard to conservation and drought resiliency, VRWD encourages the Casitas Board to follow their established policies in the WEAP and implement a Stage 4 Drought Declaration now.

Respectfully,
VENTURA RIVER WATER DISTRICT



Peggy Wiles, President

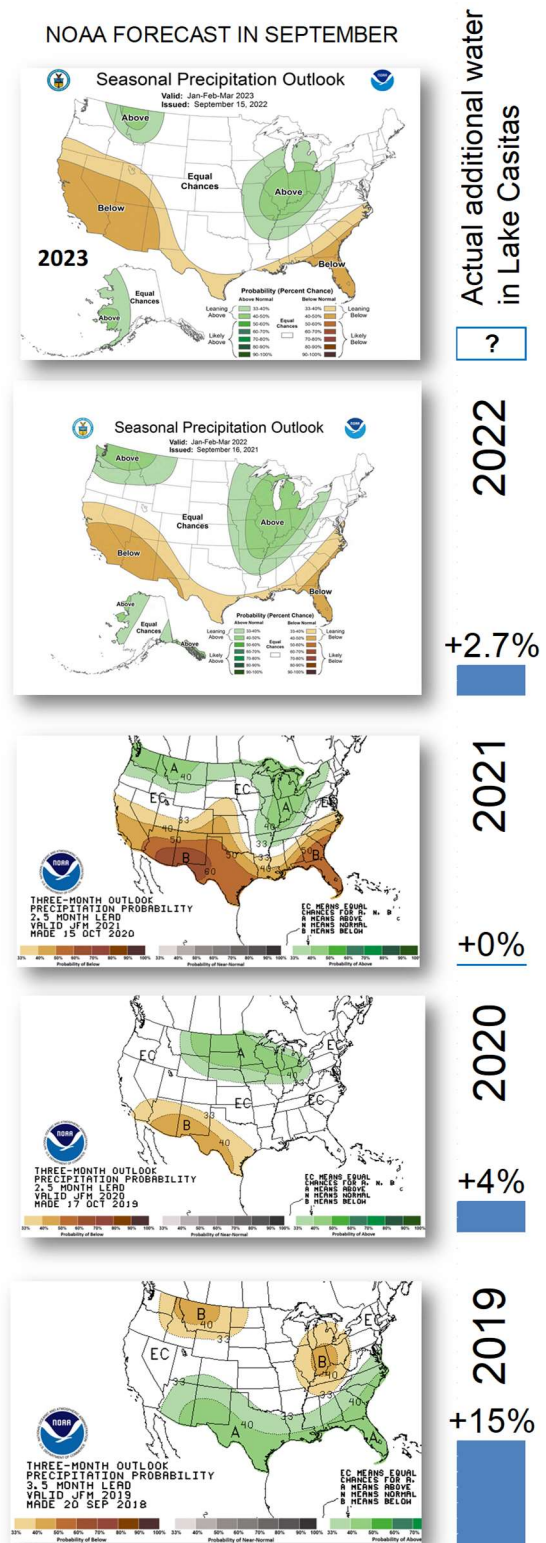

Figure 3: National Weather Service Forecasts for 2018 through 2022 with yield into Lake Casitas.