

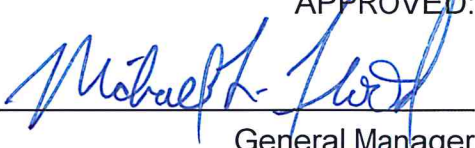

STANDARD DETAILS AND SPECIFICATIONS
FOR THE
CONSTRUCTION OF WATER MAINS AND FACILITIES
MARCH 2021

APPROVED:



General Manager

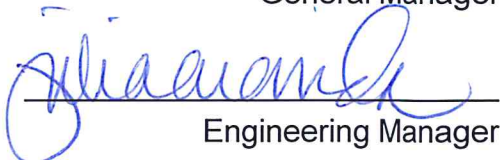

Engineering Manager



Operations and Maintenance Manager

Owner of this manual is responsible to obtain the most recent version from the Casitas Municipal Water District website prior to the start of any project within the District's service area.

This manual is not a textbook nor a substitute for engineering knowledge, experience or judgment. Neither does it impose any standard of conduct or duty to the public. Instead, the methods and procedures contained in this manual should be reviewed by the engineer using them to determine applicability to a specific project. When methods and procedures are not applicable, the engineer should request guidance from the District.

This manual is intended for use by private Owners who retain a Contractor to install facilities which will be transferred to the District. These specifications may also be used for District-funded capital projects in which the District retains a Contractor. In this case, these specifications will be used in conjunction with the Contract Documents. In the event there are discrepancies between the Contract Documents and these specifications, the Contractor shall seek clarification from the District.

Table of Contents

1	DEFINITIONS	1
2	TERMS	2
3	ABBREVIATIONS	2
4	REFERENCES	3
	4.1 General Codes or Specifications.....	3
5	MATERIALS	6
	5.1 TESTING AND FINAL ACCEPTABILITY OF MATERIAL.....	6
	5.2 MAIN LINE PIPE MATERIALS	7
	5.2.1 PVC Pipe.....	7
	5.2.2 Steel Pipe.....	9
	5.2.3 Ductile Iron Pipe.....	15
	5.3 MAIN LINE FITTINGS	15
	5.3.1 Gray-Iron and Ductile Iron Fittings	15
	5.3.2 Flanges	16
	5.3.3 Above Ground Bolts and Nuts	16
	5.3.4 Gaskets	16
	5.3.5 Flexible Couplings	17
	5.3.6 Grooved-End Couplings.....	17
	5.3.7 Transition Couplings	17
	5.3.8 Flanged Coupling Adapters	17
	5.3.9 Insulating Couplings.....	17
	5.3.10 Special Steel Pipe Fittings and Fitting Dimensions	17
	5.3.11 Mechanical Restraint Joints.....	18
	5.4 MAIN LINE VALVES	18
	5.4.1 Butterfly Valves	18
	5.4.2 Gate Valve, Wedge and Resilient-Seated Gate Valves.....	20
	5.4.3 Tapping - Sleeves and Valves	21
	5.5 EARTHWORK	21
	5.5.1 Pipe Zone.....	21
	5.5.2 Sheet piling, Shoring and Bracing of Trenches.....	22
	5.5.3 Imported Sand – Pipe Zone and Pipe Bedding.....	22
	5.5.4 Rock Fill for Foundation Stabilization.....	22
	5.5.5 Native Earth Backfill – Trench Zone	22
	5.5.6 Special Slurry Backfill	22
	5.5.7 Asphalt Concrete Paving.....	22
	5.6 CONCRETE AND MORTAR WORK.....	22

5.6.1	Design Criteria.....	23
5.6.2	Cement Mortar Lining and Coating (CMLC).....	23
5.6.3	Concrete Admixtures.....	23
5.6.4	Reinforcing Steel.....	23
5.6.5	Embedments.....	23
5.6.6	Forms.....	23
5.6.7	Curing Compound.....	24
5.7	PAINTING.....	24
5.7.1	Steel, cast iron and other bitumen coated metals.....	24
5.8	SERVICE LINE MATERIALS AND FITTINGS.....	25
5.8.1	Copper Pipe.....	25
5.8.2	Service Saddles.....	26
5.8.3	Hot Tapping.....	26
5.8.4	Abandonment of Water Service Lines.....	26
5.8.5	Corporation Stops.....	27
5.8.6	Angle Meter Stops.....	27
5.8.7	Angle Meter Stop Adapters.....	27
5.8.8	Customer Hand Valves.....	28
5.8.9	Meter Boxes.....	28
5.8.10	Double Check Valves.....	28
5.8.11	Fire hydrants.....	28
5.8.12	Combination Air Release Assemblies.....	30
5.8.13	Blow-off Assemblies.....	31
6	CONSTRUCTION.....	31
6.1	General Requirements.....	31
6.1.1	Protection/Operation of Existing Water System.....	32
6.1.2	Quality of Materials.....	32
6.1.3	Construction Water.....	33
6.1.4	Substitutions.....	33
6.1.5	Quality of Workmanship.....	33
6.1.6	Supervision and Superintendence.....	33
6.1.7	Defective Work.....	33
6.1.8	District Inspection, Field Acceptance and Guarantee Period ...	33
6.1.9	Public Relations.....	34
6.1.10	Sanitation.....	35
6.1.11	Cleanup and Dust Control.....	35
6.1.12	Observation of Work by Public Agencies.....	35
6.1.13	Safety.....	35
6.1.14	Traffic Control Devices and Signs.....	36
6.2	PERMITS.....	36
6.2.1	Encroachment.....	36
6.2.2	Easements.....	36

6.3	UTILITIES AND EXISTING FACILITIES	36
6.3.1	Utilities and Existing Facilities.....	36
6.3.2	Separation Requirements for Water and Wastewater Lines.....	37
6.4	EARTHWORK/CLEARING AND GRUBBING	37
6.4.1	General.....	37
6.4.2	Obstructions.....	37
6.4.3	Oak Tree Ordinance	38
6.4.4	Working Area.....	38
6.4.5	Clearing and Grubbing	38
6.4.6	Grading and Stockpiling.....	38
6.4.7	Imported Backfill Material	38
6.4.8	Relative Compaction.....	38
6.4.9	Compaction Tests	38
6.4.10	Correction of Faulty Grades.....	39
6.4.11	Soil Sterilant	39
6.4.12	Final Clean-up	39
6.4.13	Seeding.....	39
6.5	EXCAVATION AND TRENCHING	39
6.5.1	Safety Precautions.....	39
6.5.2	Alignment and Grades.....	39
6.5.3	Foundation in Poor Soil.....	40
6.5.4	Trench Width	40
6.5.5	Pipe Subgrade	40
6.5.6	Dewatering.....	41
6.6	PIPE BEDDING AND LAYING FOR PVC, DI, AND STEEL PIPE	41
6.6.1	General.....	41
6.6.2	Pipe Indicator Tape	42
6.6.3	Pipe Laying for PVC Pipe C900 and C905.....	42
6.6.4	Pipe Laying For Steel Pipe	43
6.6.5	Pipe Laying for Ductile Iron Pipe	47
6.7	BACKFILL AND COMPACTION FOR PVC, DI AND STEEL PIPE	47
6.7.1	General.....	47
6.7.2	Backfilling Pipe Zone.....	47
6.7.3	Jetting Method in the Pipe Zone	47
6.7.4	Backfilling Above Pipe Zone.....	48
6.7.5	Compaction Tests	48
6.8	THRUST BLOCKS AND ANCHOR BLOCKS.....	48
6.8.1	Concrete Thrust and Anchor Blocks.....	48
6.9	RESURFACING AND RESTORATION.....	49
6.10	HOT TAPPING	49
6.10.1	Hot Tapping Contractors.....	49
6.11	SERVICE CONNECTIONS AND SERVICE LINES.....	50
6.11.1	Service Taps.....	50

6.11.2 Dielectric Connections	50
6.11.3 Earthwork	50
6.12 INSTALLATION OF VALVES AND FITTINGS	50
6.13 INSTALLATION OF FIRE HYDRANT ASSEMBLIES.....	51
6.14 INSTALLATION OF METER BOXES.....	51
6.15 PAINTING.....	51
6.16 ABANDONMENT	52
6.17 HYDROSTATIC TESTING OF WATER MAINS.....	52
6.17.1 General Requirements.....	52
6.17.2 Flushing.....	52
6.17.3 Preparation	53
6.17.4 Procedure	53
6.17.5 Leakage.....	53
6.18 DISINFECTION, SAMPLING, AND ANALYSIS.....	54
6.18.1 Repetition of Procedure	55
7 STANDARD DETAILS	56

TABLES

1	Hydrostatic Test Pressures for PVC Pipe
2	Steel Pipe Standards
3	Minimum Wall Thickness for Steel Pipe
4	Nominal Dimensions for Steel Cylinders up to 12-inches in diameter
5	Cement Mortar Lining Thickness for Steel Pipe
6	Cement Mortar Coating Thickness for Steel Pipe
7	Flange Specifications
8	Approved Butterfly Valves
9	Approved Gate Valves
10	Coating Requirements for Potable Water Facilities
11	Service Line Materials and Fittings
12	Approved Tapping Saddles
13	Angle Meter Stops
14	Angle Meter Stop Adapters
15	Customer Hand Valves
16	Meter Boxes
17	Fire Hydrant Assemblies
18	Air and Vacuum Valve Assemblies
19	Trench Widths
20	Pipe Layout for Curved Alignment
21	Welding for Steel Pipe

This page left intentionally blank.

1 DEFINITIONS

Agreement: The executed form of letter agreement between the District and the Owner in which the Owner agrees to construct facilities which, when constructed to these Specifications, will be accepted and owned by the District; or the Agreement between a Contractor and the District for the construction of District facilities.

Contract Documents: The Notice Inviting Bids, Bid Documents, Bonds, Agreement, General Conditions, Special Conditions, Technical Specifications, Drawings, and Addenda which document the scope of work and terms for a District-funded construction project.

Contractor: The licensed Contractor either engaged by the Owner to construct facilities for acceptance by the District, or who has directly entered an Agreement with the District for the performance of work and the construction of District facilities.

District: CASITAS MUNICIPAL WATER DISTRICT, a municipal water district established in 1952, 1055 North Ventura Avenue, Oak View, California, 93022.

District Representative: The person or engineering firm appointed by the Board of Directors of the District to represent the District.

Drawings: The official plans, profiles, typical cross-sections, working drawings, detail drawings and supplemental drawings, or exact reproductions thereof, approved by the District, which show the locations, character, dimensions, and details of the work to be done.

Engineer: The General Manager of Casitas Municipal Water District or his/her duly authorized Representative.

Groundwater: Subsurface water found in the saturation zone.

Laboratory: The laboratory designated by the District's Representative and/or District to test materials and work involved in the Contract.

Mechanical Joints: Bolted joints.

Owner: Legal property owner of parcel(s) to whom water service is/will be provided by Casitas Municipal Water District.

Rated Working Pressure or Pressure Class: A pipe classification system based upon the internal working pressure of the fluid in the pipe, type of pipe material and the thickness of the pipe wall.

Specifications: The directions, provisions, requirements, and standard details pertaining to

the method and manner of performing the work, and to the qualities of materials to be furnished for acceptance by the District. May also be referred to herein as “Standards”.

Standard Details: Casitas Municipal Water District Standard Details.

2 TERMS

Wherever the terms “required”, “permitted”, “ordered”, “designated”, “directed”, “prescribed”, or similar terms are used, it shall be understood the requirements, permission, order, designation, prescription, or direction of the District Representative is intended. Similarly, the terms “acceptable”, “satisfactory”, “or equal”, or similar terms shall mean acceptable to or satisfactory to the District Representative, unless otherwise expressly stated. The word “provide” shall be understood to mean furnish and install.

3 ABBREVIATIONS

AASHTO	American Association of State Highway and Transportation officials
ANSI	American National Standards Institute
APWA	American Public Works Association
ASME	American Society of Mechanical Engineers
ASTM	American Society for Testing and Materials
AWS	American Welding Society
AWWA	American Water Works Association
CMLC	Cement mortar lined and coated
DI	Ductile iron
DR	Dimension Ratio
FIP	Female Iron Pipe
HDPE	High-density polyethylene
mg/l	Milligrams per liter
MIP	Male Iron Pipe
NPDES	National Pollutant Discharge Elimination System
OSHA	Occupational Safety and Health Administration
OD	Outside diameter
PC	Pressure class
ppm	Parts per million
psi	Pounds per square inch
PVC	Polyvinyl chloride
State	California Standard Specifications, State of California, Department of Transportation, Division of Highways (Caltrans)
SWRCB	State Water Resources Control Board
TMDL	Total Maximum Daily Load
UL	Underwriter Labs

4 REFERENCES

4.1 General Codes or Specifications

- Standard Specifications for Public Works Construction 2018 Edition, by APWA, the “Green Book.”
- Standard Specifications State of California Business and Transportation Agency, Department of Transportation Standard Specifications (Caltrans), latest edition.
- State of California Department of Industrial Relations, Division of Industrial Safety, “Construction Safety Orders” (Shoring), latest edition.
- City Standards, City of San Buenaventura, California.
- County of Ventura Public Works Agency Road Standards, Ventura, California, latest edition.

ASTM Specifications:

A126	Standard Specification for Gray Iron Castings for Valves, Flanges, and Pipe Fittings
A185	Standard Specification for Welded Steel Wire Fabric for Concrete Reinforcement.
A193	Standard Specification for Alloy-Steel and Stainless Steel Bolting for High Temperature or High Pressure Service and Other Special Purpose Applications
A194	Standard Specification for Carbon Steel, Alloy Steel, and Stainless Steel Nuts for Bolts for High Pressure or High Temperature Service, or Both
A233	Standard Specification for Mild Steel Covered Arc-Welding Electrodes
A307	Standard Specification for Carbon Steel Bolts, Studs, and Threaded Rod
A436	Standard Specification for Austenitic Gray Iron Castings
A536	Standard Specification for Ductile Iron Castings
A570	Standard Specification for Hot-Rolled Carbon Steel Sheet and Strip, Structural Quality
A615	Standard Specification for Deformed and Plain Carbon-Steel Bars for Concrete Reinforcement
A668	Standard Specification for Steel Forgings, Carbon and Alloy, for General Industrial Use
A1011	Standard Specification for Steel, Sheet and Strip, Hot Rolled, Carbon, Structural, High-Strength, Low-Alloy, High-Strength Low-Alloy with Improved Formability, and Ultra-High Strength
B61	Standard Specification for Steam or Valve Bronze Castings
B62	Standard Specification for Composition Bronze or Ounce Metal Castings
C33	Standard Specification for Concrete Aggregates

C94	Standard Specification for Ready-Mixed Concrete
C150	Standard Specification for Portland Cement
C309	Standard Specification for Liquid Membrane-Forming Compounds for Curing Concrete
C685	Concrete Made by Volumetric Batching and Continuous Mixing
D698	Standard Test Methods for Laboratory Compaction Characteristics of Soil Using Standard Effort
D1248	Standard Specification for Polyethylene Plastic Extrusion Materials for Wire and Cable
D1557	Standard Test Methods for Laboratory Compaction Characteristics of Soil Using Modified Effort
D2419	Standard Test Method for Sand Equivalent value of Soils and Fine Aggregate

AWWA Manuals:

M6	Water Meters: Selection, Installation, Testing and Maintenance.
M11	Steel Pipe: A Guide for Design and Installation
M17	Fire Hydrants: Installation, Field Testing and Maintenance
M22	Sizing Water Service Lines and Meters
M23	PVC Pipe Design and Installation
M41	Ductile Iron Pipe and Fittings
M44	Distribution Valves: Selection, Installation, Field Testing, and Maintenance
M51	Air Valves, Air Release, Air/Vacuum, and Combination

AWWA Standards:

C104	Cement Mortar Lining for Ductile Iron and Gray Iron Pipe and Fittings for Water
C110	Ductile Iron and Gray-Iron Fittings
C111	Rubber Gasket Joints for Ductile Iron Pressure Pipe And Fittings
C115	Flanged Ductile Iron Pipe with Ductile-Iron or Gray-Iron Threaded Flanges
C150	Thickness Design of Ductile Iron Pipe
C151	Ductile Iron Pipe, Centrifugally Cast
C153	Ductile Iron Compact Fittings
C200	Steel Water Pipe 6 Inches and Larger. Note - Steels to be ASTM A283 or A570.
C205	Cement-Mortar Protective Lining and Coating for Steel Water Pipe, 4-In. and Larger, Shop Applied. Note - Cement to meet ASTM C150
C206	Field Welding of Steel Water Pipe. Note - Welding Electrodes to meet ASTM A233 and Welding Procedures to meet AWS D10.9
C207	Steel Pipe Flanges for Water Works Service - Sizes 4-In. through 144-In.
C208	Dimensions for Fabricated Steel Water Pipe Fittings

C223	Fabricated Steel and Stainless Steel Tapping Sleeves
C500	Metal-Seated Gate Valves for Supply Service
C503	Wet-Barrel Fire Hydrants
C504	Rubber-Seated Butterfly Valves
C509	Resilient-Seated Gate Valves for Water Supply Service
C550	Protective Interior Coatings for Valves and Hydrants
C600	Installation of Ductile Iron Mains and Their Appurtenances
C602	Cement Mortar Lining of Water Pipelines in Place – 4 in. and Larger
C604	Installation of Buried Steel Water Pipe – 4 in. and Larger
C605	Underground Installation of Polyvinyl Chloride (PVC) and Molecularly Oriented Polyvinyl Chloride (PVCO) Pressure Pipe and Fittings
C606	Grooved and Shouldered Joints
C651	Disinfecting Water Mains
C900	Polyvinyl Chloride (PVC) Pressure Pipe and Fabricated Fittings, 4-In. Through 12-In., for Water
C905	Polyvinyl Chloride (PVC) Pressure Pipe and Fabricated Fittings, 14-In. through 48-In., for Water Transmission and Distribution

5 MATERIALS

This section discusses the materials involved in potable water systems and associated construction activities.

The materials selected were chosen for their strength, durability, and ease of maintenance. In some instances, the District's requirements exceed those of the industry or regional standards. Where applicable, industry or regional standards, such as AWWA or other standards, are referenced and it is the responsibility of the Contractor to be familiar with those standards to insure compliance. Titles corresponding to the specific numbers are given in the reference section of the standards.

All equipment, materials, and supplies to be incorporated in the work shall be new unless otherwise specified.

Contractor is to follow manufacturer's recommendations for storage in order to prevent material damage. Failure to do so will be a cause for the District to reject such improperly stored materials.

In some instances, particular manufacturers and product names are mentioned as being approved. Other products may also meet the requirements, but must be first approved in writing by the District before delivery and before such material is used in the work. One factor which may be considered by the District in any consideration of other products is the need for some degree of standardization. In the event the Contractor furnishes the material, process, or article better than that specified, the difference in cost of such material, process, or article so furnished shall be at no expense to the District.

5.1 TESTING AND FINAL ACCEPTABILITY OF MATERIAL

The District will require tests and certifications as deemed necessary to show the specified materials have been employed. Notwithstanding prior factory or yard inspections, the District Representative shall have the right to reject any damaged or defective materials found on the job which will affect the durability or performance of the installation, and order its removal from the site.

No materials shall be installed until approved by the District. All installations which are to be backfilled shall be inspected and approved by the District's Representative prior to backfilling and the Contractor shall give 24 hours' notice in advance of backfilling to the District's Representative so proper inspection may be provided.

All materials not conforming to the requirements of these specifications shall be considered as defective and all such materials, whether in place or not, shall be rejected.

The inspection of the work shall not relieve the Contractor of any obligations to fulfill the specifications as prescribed. Defective work shall be made good, and unsuitable materials may be rejected notwithstanding the fact that such defective work and unsuitable materials were previously overlooked by the District's Representative and accepted.

All materials for use in the work shall be stored by the Contractor in such a manner as to prevent damage from exposure to the elements, admixture of foreign materials, or from any other cause. The District is not responsible for damage or loss of materials by weather or other causes.

5.2 MAIN LINE PIPE MATERIALS

5.2.1 PVC Pipe

Polyvinyl chloride (PVC) pipe shall conform to the quality and strength requirements of AWWA C900-16, C905-10 and C905-97.

Each standard or random length of pipe shall be clearly marked with the following:

- Nominal size and outside diameter (OD) base, e.g., six-inch cast iron pipe size.
- Material code "PVC 1120."
- Dimension Ratio, e.g., DR 25, where the DR is equal to the outside diameter divided by the pipe thickness.
- AWWA pressure class, i.e., PC 150.
- AWWA designation "AWWA C900" or "AWWA C905".
- Manufacturer's trade name and production record code.
- Seal (mark) of testing agency.

The standard laying length shall be 20 feet (plus/minus one inch) in all classes and sizes. Pressure rating shall be as determined by the District Representative.

For Class 150 and 200 (C900 and C905, respectively) pipe, the minimum short piece of pipe length shall be two feet unless prior approval is received from the District Representative.

Sections 5.8.3 and 6.10 of these Standards include hot-tapping requirements.

"Heavy wall tap couplings" or "threaded brass insert couplings" are not accepted.

AWWA C900 and C905 pipe has the same outside diameter (OD) as that of ductile iron pipe in the sizes furnished.

One gasket shall be furnished with each length of elastomeric-gasket bell-end pipe and two gaskets shall be furnished with each coupling where couplings are used.

Pipe surfaces shall be free from nicks, scratches and other blemishes. The joining surfaces of pipe spigots and of integral bell and sleeve reinforced bell sockets shall be free from gouges or other imperfections that might cause leakage.

Approved PVC pipe is:

- Vinyl Tech
- Diamond Plastics C900

Other manufacturers require prior approval by the District.

5.2.1.1 Joint Mechanisms

The joints must meet DR requirements and shall be one of the following:

- Integral wall - thickened bell end (bell and spigot with rubber gasket.)
- Integral sleeve reinforced bell end
- Elastomeric gasket couplings

PVC solvent cement joints, although allowed by AWWA C900 and C905, must receive prior approval from the District Representative.

5.2.1.2 Couplings and Fittings

Where couplings are used, they shall meet the requirements of AWWA C900 and C905. Couplings shall be as furnished by the manufacturer and shall be marked with same information as the pipe. Couplings with no stops shall only be used at closures.

5.2.1.3 Cast Iron Fittings

Cast iron fittings with grip-tite ends shall be used for PVC pipe are described in Section 5.3.1.

5.2.1.4 Locating Wire

Copper wire shall be provided, which shall be 12 gauge, single strand, with 30 mil high-density polyethylene (HDPE) insulation, blue in color. Adhesive tape shall be Polyken No. 900 or Scotchrap No. 50.

5.2.1.5 Pipe Indicator Tape

Pipe indicator tape shall be 4.5-mil solid aluminum foil imprinted with the warning "CAUTION – WATER LINE BURIED BELOW" on both sides, completely encased to prevent ink rub-off. Tape shall be three inches wide and shall be blue with black ink per APWA standards.

5.2.1.6 Physical Test Requirements.

Hydrostatic, burst, and sustained pressure and crushing tests shall be conducted at the factory in accordance with AWWA C900-16 and C905-97. All testing shall be done by a

recognized testing laboratory with such testing available for inspection by the District. If required, the manufacturer shall supply a letter of certification attesting to their pipe meeting these specifications. The hydrostatic proof test for every piece of pipe shall be as shown in Table 1.

Table 1
Hydrostatic Test Pressures for PVC Pipe

Pipe Class	Dimension Ratio (DR)	Pressure Rating (psi)
C900	DR = 18 or Class 150	235
	DR = 14 or Class 200	305
C905	41	200
	32.5	250
	26	320
	25	330
	21	400
	21	400
	18	470

5.2.2 Steel Pipe

All welding shall be done by qualified welders as specified in AWWA C200, C205, C206, C207, C208 and the Standards of the American Welding Society (AWS). Certification per American Society of Mechanical Engineers (ASME) Section IX is mandatory. Provide proof of valid certification to the District Representative prior to commencing work.

Steel pipe shall conform to the quality and strength requirements of AWWA C200 or as specified below. That standard pertains to electrically butt-welded straight-seam or spiral-seam pipe and to seamless pipe six inches in diameter or larger. The steel shall conform to one of the standards shown in Table 2.

Table 2
Steel Pipe Standards

Specification	Grade	Minimum Yield Point (psi)
ASTM A668	Grade C	30,000
	Grade D	33,000
ASTM A1011	Grade 30	30,000
	Grade 36	36,000
	Grade 40	40,000
	Grade 45	45,000

The stress in the steel pipe shall not exceed the higher of 15,000 psi or the stress computed using one-half the designated working pressure and the stress formula below except that the minimum thicknesses shown in Table 3 shall be used.

Table 3
Minimum Wall Thickness for Steel Pipe

Nominal Inside Diameter (Inches)	Minimum Thickness (Inches)
4 to 18	0.1046
20 and 21	0.1345
24 and 27	0.1495

Larger diameter steel pipe shall have wall thickness as shown on the Drawings or Contract Documents. The following formula shall be used to determine the stress in the steel cylinder:

$$s = \frac{PD_i}{2g}$$

Where:

- s = Stress, psi
- P = Working Pressure, psi
- D_i = Maximum Inside Diameter of Steel Cylinder, inches
- g = Wall Thickness of Steel Cylinder, inches

The gauges specified above consider the thicknesses required for welding as well as that required for external loads and a corrosion allowance.

The nominal measurements for steel cylinders 12 inches and smaller shall conform to Table 4.

Table 4
Nominal Dimensions for Steel Cylinders up to 12-inches in diameter

Nominal Inside Diameter (inches)	Nominal Outside Diameter (inches)
4	4.5
6	6.625
8	8.625

Table 4
Nominal Dimensions for Steel Cylinders up to 12-inches in diameter

Nominal Inside Diameter (inches)	Nominal Outside Diameter (inches)
10	10.75
12	12.75

For larger pipes, the steel cylinder outside diameter shall be computed using the following formula:

$$D_o = D + 2 (t+g)$$

Where:

- D_o = Actual Steel Cylinder OD, inches
- D = Nominal Inside Diameter, inches
- t = Thickness of Cement Mortar Lining, inches
- g = Wall Thickness of Steel Cylinder, inches

Another factor for consideration in all steel lines is earth loads. AWWA Manual M11 should be consulted in this regard.

The pipe shall be essentially round. The outside circumference shall not vary more than plus/minus 1.0 percent from the nominal outside circumference based upon the diameter specified (except for the ends which are discussed in Section 5.2.2.1.)

The pipe lengths, generally 40 feet long, shall be furnished with a tolerance of plus/minus two inches. Random lengths shall be furnished in lengths averaging 29 feet or more, with a minimum length of 20 feet.

Seams in steel cylinders shall be fusion, longitudinal, spiral, or girth welded. Longitudinal seams shall be limited to not more than one per plate section. Longitudinal seams must be staggered with longitudinal seams in adjoining plate section. Girth seams shall be limited to one per standard section 16 feet or less in length.

Additional girth seams in longer standard sections may be employed but not to exceed one per each additional full 10 feet beyond the first 20 feet. Seams in special sections may be increased as required.

5.2.2.1 Pipe Ends

Various end treatments can be supplied as discussed in AWWA C200 and are briefly listed below:

- Ends for mechanical coupled field joints, which may be either plain or grooved.

- Ends for lap joints for field welding shall have a bell end pressed or rolled without hammering. The surfaces shall be ground smooth. When assembled, joints must have a minimum 1½ -inch lap with approximately 1/32-inch clearance.
- Plain end pipe shall have a plain end right angle cut.
- Except for butt strap closures, butt welding and field fabricated fittings are not permitted unless approved by the District.
- Deflection of more than three (3) degrees not allowed at joints.
- Ends fitted with butt straps for field welding. The butt straps may be made in halves. Wedding bands shall not be used unless approved in advance by the District Representative.
- Bell-and-spigot ends with rubber gaskets shall have bell ends which are made without hammering. Spigot ends shall be formed or fabricated to the required shape to retain the gasket. The gasket shall be designed and fitted as the sole element dependent upon to make the joint water tight. The gasket shall meet the requirements of AWWA C200.
- Plain ends fitted with flanges.

The allowable tolerance at pipe ends is discussed in AWWA C200.

5.2.2.2 Hydrostatic tests

Each pipe shall be tested by the manufacturer to a pressure not less than that determined by:

$$S = \frac{PD_i}{2g}$$

where S = 0.75 times the minimum yield strength of the steel and the other items are as discussed previously.

5.2.2.3 Cement Mortar Lining and Coating (CMLC)

Unless otherwise approved or as revised below, all steel pipe shall be cement mortar lined and coated in accordance with AWWA C205 and ASTM C150 which covers shop applied lining and coating. Cement shall be Portland cement Type II for lining and coating.

Cement mortar lining shall be uniform in thickness except at joints or other discontinuities. Ends of lining shall be left square and uniform and the lining holdback shall be as specified for the particular type of joint.

District requirements for thickness exceed those of the AWWA standard. No wire fabric reinforcement is required for any lining of specials less than 24 inches in diameter. Cement mortar lining thickness shall be as shown in Table 5.

Table 5
Cement Mortar Lining Thickness for Steel Pipe

Nominal Pipe Size (inches)	Lining Thickness (inches)	Tolerance (inches)
6 to 12	5/16	-1/16 + 1/8
14 to 16	3/8	-1/16 + 1/8
18 to 36	1/2	-1/16 + 1/8

For larger diameter steel pipe, cement mortar coating shall be as shown on the Drawings or in the Contract Documents.

Cement mortar coating shall be a reinforced coating over all outside surfaces of the pipe and specials. The coating shall be of a uniform thickness except at joints or other discontinuities in the pipe. Ends of coatings shall be left square and uniform and the coating holdback shall be as specified for the particular type of joint. Cement mortar coating thickness shall be as shown in Table 6.

Table 6
Cement Mortar Coating Thickness for Steel Pipe

Nominal Pipe Size (inches)	Coating Thickness (inches)	Tolerance (inches)
4 to 6	1/2	-0 + 1/8
8 to 10	3/4	-0 + 1/8
12 and above	1	-0 + 1/8

After inspection of welded joints and electrically bonded connections, the outside joint recess shall be coated.

Flanges shall be coated with Sanchem NO-OX-ID per Section 5.7 and in accordance with AWWA C205.

5.2.2.4 Electrically Bonded Connections

All unwelded steel pipe joints shall have jumper bond connections. Material and shape shall be as shown on Drawings or in Contract Documents.

5.2.2.5 Factory Tests and Inspection

The District Representative shall at all times have the right to inspect the work and materials during the manufacturing process and to make or witness such tests as required in these specifications, or as deemed advisable. The Contractor will then

perform any and all additional work required to assure the pipeline is electrically continuous. In lieu of the preceding, the Contractor shall upon request submit a certificate certifying the materials meet the requirements of this specification. All testing will be done in recognized testing laboratories within the State of California approved by the District Representative.

5.2.2.6 Fabricated Angles

Fabricated angles shall meet the requirements of AWWA C208. Except for butt strap closures, field fabricated fittings are not permitted unless approved by the District Representative.

5.2.2.7 Welded Joints

One of each section shall be swaged out to form a female or bell end which shall permit the male or spigot end to enter approximately 12 inches with a minimum clearance of 1/32-inch. The spigot end shall be "sized" to permit it to enter the bell end of the adjacent section and the weld bead shall be ground flush for the distance it is to enter the bell end.

5.2.2.8 Butt Strap Closures

The butt straps shall be the same thickness as the pipe wall but not less than six gauge, at least 10 inches wide with longitudinal seams, rolled to fit the outside cylinder diameter and shall be centered over the ends of the pipe sections they are to join. A standard five-inch steel coupling shall be welded to the top section of the butt strap to permit access for mortar lining the inside of the joint. The coupling shall be closed with a five-inch solid steel plug welded to the coupling.

5.2.2.9 Welding electrodes

Welding electrodes shall comply with the Standards of the AWS. After the joints have been welded, the joint shall be coated in the same manner as specified for rubber ring joints in Section 6.6.4.3.

5.2.2.10 Shop Drawings

Shop drawings of all pipe and fittings shall be submitted to the District's Representative for approval prior to fabrication of the pipe and fittings. Pipe lay sheets shall be included, consisting of drawings of lay, identification of joints, horizontal and vertical angles and appurtenances. Stationing and elevation shall be shown on all joints, angles and appurtenances. Elevation shall consist of top of pipe and finished surface at these points. Format for shop drawings and lay sheets may be obtained from the District Representative. Such approval is an additional precaution against errors and is not to be construed as relieving the Contractor of the full responsibility for the accuracy of the shop drawings.

Fabricated angles shall meet the requirements of AWWA C208.

5.2.2.11 Pipe Markings

Markings shall include a designation mark for each pipe or fitting furnished and field top

shall also be indicated.

5.2.2.12 Pipe Indicator Tape

Pipe indicator tape shall be 4.5-mil solid aluminum foil imprinted with the warning "CAUTION – WATER LINE BURIED BELOW" on both sides, completely encased to prevent ink rub-off. Tape shall be four inches wide and shall be blue with black ink per APWA standards.

5.2.3 Ductile Iron Pipe

5.2.3.1 Pipe

Ductile iron pipe shall conform to AWWA C151 for both quality and strength. Each pipe shall include the letters "DI" or word "DUCTILE" to indicate the pipe material. The standard nominal laying length shall be 18 or 20 feet. Random and short lengths shall be per AWWA C151.

5.2.3.2 Joints

Joints shall be of the rubber gasket push-on joint type conforming to the requirements of AWWA C111 unless otherwise specified. If required, the manufacturer shall supply a letter of certification attesting to their pipe meeting these specifications.

5.2.3.3 Service Line Taps

For 1-inch and 2-inch service line taps, service saddles are required. For larger sizes, contact the District representative. Tapping of the main pipeline is not allowed.

5.2.3.4 Lining and Coating

Unless otherwise approved, the internal surfaces shall be lined with a uniform thickness of cement mortar and then sealed with a bituminous coating in accordance with AWWA C104.

5.2.3.5 Pipe Indicator Tape

Pipe indicator tape shall be 4.5-mil solid aluminum foil imprinted with the warning "CAUTION – WATER LINE BURIED BELOW" on both sides, completely encased to prevent ink rub-off. Tape shall be three inches wide and shall be blue with black ink per APWA standards.

5.3 MAIN LINE FITTINGS

5.3.1 Gray-Iron and Ductile Iron Fittings

Fittings shall be cement mortar lined or epoxy lined and shall meet the requirements of AWWA C104, C110, C111, C153 and C200. The pressure rating shall be as determined by the District Representative. This standard covers, but is not limited to, fittings with combinations of ends including mechanical joints, plain end, flanged, and push on joints. The fitting types are as follows:

- 90° bend, 45° bend, 22½° bend, 11¼° bend.

- Tees, crosses, reducers, caps, plugs, connecting pieces, flanged bends, flanged tees, flanged crosses, flanged reducers.

Unless otherwise approved, the internal surfaces shall be lined and manufactured to exceed the minimum requirements of AWWA C151/ANSI A21.51-96.

Care must be exercised to not mix mechanical and flange joint ends since they will not mate.

5.3.2 Flanges

Per AWWA C206, C207 and C208, flanges shall be flat-faced and meet the requirements of AWWA C207 and should be AWWA standard steel hub flanges (these flanges meet ANSI B-16.5.) The flanges shall be marked with the size, name, and trademark of manufacturer and with the AWWA class, i.e., "E".

Flanges shall comply with the specifications shown in Table 7.

Table 7
Flange Specifications

Working Pressure (psi)	Specification	Class
0 – 275	AWWA C207 and ANSI B-16.5	E (flat face)
0 – 300	AWWA C207 and ANSI B-16.5	F (flat face)

Higher class flanges are required when necessary to match valves.

5.3.3 Above Ground Bolts and Nuts

Bolts and nuts for aboveground installations shall be cadmium plated and shall conform to ASTM A307, Grade B, when a ring gasket is used and shall conform to ASTM A193 when a full-face gasket is used. Bolts and nuts shall be heavy hexagon series. Nuts shall conform to ASTM A194 either in Grade 1, 2 or 2H. The fit shall be ANSI B1.1 Class 2, except that Class 3 fit shall be used in holes tapped for studs. Threads may be made either cutting or cold forming. Between 3-inch and 12-inch shall project through the nut when drawn tight. Bolts for underground installations shall be hot-dip galvanized. All buried bolts shall be completely coated with Sanchem NO-OX-ID or appropriate equal, which must be applied in two coats to a minimum thickness of 15 millimeters per coat.

5.3.4 Gaskets

Gaskets shall be of the full face gasket type, 1/16-inch thick where both flanges are flat; drop in gaskets may be used with prior District approval. Drop-in gasket type 1/16-inch may be used where a raised face flange is present.

[5.3.4.1 Class "E" Flanges](#)

Cloth-inserted rubber. Gaskets shall be suitable for a pressure of 350 psi at a temperature of 180 degrees F.

[5.3.4.2 Class "F" Flanges](#)

Acrylic or aramid fiber bound with nitrile. Products: Garlock Bluegard, or approved equal. Gaskets shall be suitable for a water pressure of 740 psi at a temperature of 100 degrees F. Gaskets shall comply with ANSI B16.20.

[5.3.5 Flexible Couplings](#)

Flexible couplings are designed to connect plain end pipes with a mechanical compression joint to provide a stress relieving, flexible, leak-proof joint. Their use must be approved by the District Representative prior to ordering/installing couplings. They can be ordered in steel or cast iron pipe sizes (note: C900 and C905 PVC pipe has same outside diameter as cast iron.) The couplings shall either be Romac XR501, Romac Macro HP, or approved equal.

[5.3.6 Grooved-End Couplings](#)

Grooved-end couplings shall be of the two-piece style housing, Victaulic Style 75, 77 or approved equal conforming to AWWA C606. Pipe shall be square cut grooved. Gasket shall be suitable for potable water. This type coupling shall not be used for burial service. Couplings shall be painted the same color as the pipe in accordance with Section 5.8.1 of these Standards.

[5.3.7 Transition Couplings](#)

Transition couplings are used to connect pipes of the same nominal size but different materials. Asbestos cement, steel, and PVC pipes can be connected to one another. Mechanical joint fittings and transition rubber gaskets are not accepted unless approved the District Representative.

[5.3.8 Flanged Coupling Adapters](#)

Flanged coupling adaptors are used to connect plain end pipe to flanged valves, pumps, meters, etc. They eliminate the need for both a flanged spool and coupling. Generally, they are available in sizes through 12 inches. Approved are Romac FCA501 or approved equal.

[5.3.9 Insulating Couplings](#)

Insulating couplings are used to stop the flow of electric current across the joint by means of an insulating boot. Approved are Romac IC501.

[5.3.10 Special Steel Pipe Fittings and Fitting Dimensions](#)

AWWA C200 and C208 cover special fittings, such as elbows, tees, crosses, reducers, etc., and should be consulted for a specific application. Compact fittings are not approved. The outside surface shall be protected with Sanchem NO-OX-ID per Section 5.7 herein.

Fitting dimensions shall conform to AWWA Specification C208, except that reducers shall consist of taper sections between six-inch minimum lengths of adjoining pipe. The taper shall be a minimum of 12 inches in length of each two-inch diameter change and the gauge shall be equal to that of the larger adjoining pipe. The diameter of the six-inch sections shall match the adjoining pipes and the gauge shall be sufficient to maintain a stress of not less than 15,000 psi at the designated working pressure and shall be not less than 10 gauge.

All special sections and fittings shall be fabricated in a shop by the manufacturer from District-approved shop drawings under the inspection of a District Representative. Except for butt strap closures, field fabricated fittings are not permitted unless approved by the District Representative.

5.3.11 Mechanical Restraint Joints

Restrained joint fittings shall be provided at all tees, crosses, reducers, bends, caps, plugs and valves such that the pipe is fully restrained in all directions.

These shall be Underwriter Lab (UL) approved through 12-inch for both ductile iron and PVC. The restraint mechanism shall consist of individually activated gripping surfaces to maximize restraint capability. Twist-off nuts, sized the same as the tee-head bolts, shall be used to insure proper activating of restraining devices. The gland shall be manufactured of ductile iron conforming to ASTM A536-80. The retainer-gland shall have a pressure rating equal to that of the pipe on which it is used through 14-inch with a minimum safety factor of 2:1. Approved manufacturers: Star Pipe Products, SIP Industries, and EBAA Iron Inc.

When it is necessary to restrain push-on joints adjacent to restrained fittings, a harness restraint device shall be used. All harnesses shall have a pressure rating equal to that of the pipe on which it is used through 14-inch. Harness assemblies including tie bolts shall be manufactured of ductile iron conforming to ASTM A536-80. Approved manufacturers: Star Pipe Products, SIP Industries, and EBAA Iron Inc.

5.4 MAIN LINE VALVES

5.4.1 Butterfly Valves

Butterfly valves per AWWA C504 shall be used for general waterline use when line pressure is less than 150 psi in lines larger than 12-inches or where required by the District.

Identification copper wire used for locating PVC pipe must be installed continuously between successive valve boxes as described in Section 6.6.2.4.

5.4.1.1 General

Butterfly valves shall be tightly closing, rubber seated valves conforming to AWWA C504 except as herein modified. Valves shall be designed for tight shut-off with no water leaks when subjected to a maximum differential pressure across the disc of

150 psi.

5.4.1.2 Coating

The interior cast iron surfaces of valves, including the disc, shall be coated with 100 percent solids, catalytically setting epoxy which is manufactured for use in the interior of potable water systems and per Section 5.8. Valve bodies and operator corrosion housings shall be protected with Sanchem NO-OX-ID per Section 5.7 of these Specifications.

5.4.1.3 Operators

All valve operators shall be fully gasketed, weatherproofed and factory packed with grease. Operators shall be of the size required for opening and closing the valve against its design water pressure and shall have a torque rating not less than that shown in AWWA Specification C504.

The operator shall be capable of withstanding an input torque of 450 foot-pounds at extreme operator position without damage.

Buried operators shall be worm gear or screw type with counter-clockwise opening equipped with standard AWWA two-inch operating nuts. Operators shall be specifically designed and suitable for permanent buried service.

Operators for valves located above ground shall have disc-position indicators and hand-wheel or as specified.

5.4.1.4 Marking

The manufacturer shall show the manufacturer's name or mark, the year of manufacture, valve size and the designation of working pressure.

5.4.1.5 Approved Valves

Butterfly valves shall be from those listed in Table 8.

**Table 8
Approved Butterfly Valves**

Manufacturer	Pressure Class (psi)	Model No.
Mueller	150	Line seal III
Dezurik	150	
Dezurik	250	
AVK	150	816

5.4.1.6 Painting

All exposed metal surfaces of valves installed above ground or in vaults shall be painted per Section 5.7 and 6.15 of these Standards and in accordance with AWWA C105.

5.4.1.7 Valve Restraints

Valve restraints shall be used when installing push-on valves below ground. When placing thrust blocks around a fitting, the concrete must be around the fitting and not the joint.

5.4.1.8 Valve Stacks and Covers

Refer to Standard Detail SD-103. Christy Cover G3, Stack-8" SDR 35, or approved equal.

5.4.2 Gate Valve, Wedge and Resilient-Seated Gate Valves

Per AWWA, this specification pertains to above-ground valves three-inch and smaller and buried valves twelve-inches and smaller and shall be rated for the working pressure of the pipeline. When determined by the District Representative, high pressure wafer sphere butterfly valve or plug valve must be used regardless of main size.

Valves shall be tightly closing, rubber seated valves conforming to AWWA C500 and C509 except as herein modified. Valves shall be designed for tight shut-off with no water leaks when subjected to a maximum differential pressure across the disc of 200 psi.

Valves shall meet the requirements of AWWA C500, C509, and C550 specifications and shall be of the same size as the main in which they are installed.

All valves shall be counter-clockwise opening, non-rising stem type. Buried valves shall be equipped with two-inch square cast iron operating nuts. Valves located above ground or in vaults shall have a hand-wheel or as specified in the Contract Documents.

5.4.2.1 Coatings

The interior cast iron surfaces of valves shall be coated with 100 percent solids, catalytically setting epoxy which is manufactured for use in the interior of potable water systems and per Section 5.7 of these Standards. Valve bodies shall be protected with Sanchem NO-OX-ID per Section 5.7 herein.

5.4.2.2 Marking

The valve shall show the manufacturer's name or mark, the year of manufacture, valve size, and the designation of working pressure.

5.4.2.3 Approved valves

Gate valves shall be those listed in Table 9.

Table 9
Approved Gate Valves

Manufacturer	Pressure Rating (psi)	Model No.
Clow Resilient Wedge	200	2639-2640
Clow Resilient Wedge	250	2638
Mueller Resilient Wedge	200	A-2362
AVK Resilient Wedge	250	AVK 45/65

For higher pressure installations, contact the District Representative.

5.4.2.4 Painting

All exposed metal surfaces of valves installed above ground or in vaults shall be painted per Section 5.7 of these Standards and in accordance with AWWA C105.

5.4.2.5 Valve restraints

Valve restraints shall be used when installing push-on valves below ground. When placing thrust blocks around a fitting, the concrete must be around the fitting and not the joint.

5.4.2.6 Valve Stacks and Covers.

Refer to Standard Detail SD-103. Christy Cover G3, Stack-8" SDR35, or approved equal.

5.4.3 Tapping - Sleeves and Valves

When tapping pipe, no tapping shall be done less than two feet from a joint. Edge of sleeve must not be closer than 18 inches from a joint.

5.5 **EARTHWORK**

Earthwork shall be as listed in the Standard Specifications for Public Works Construction Latest Edition, by APWA.

Within the rights-of-way of the State Department of Transportation, the Ventura County Public Works Agency Transportation Department, the City of Ojai, and the City of Ventura, earthwork shall be in accordance with requirements and provisions of the permits issued by those agencies. Such requirements and provisions, where applicable, shall take precedence and supersede the provisions of these Specifications.

Disposal of any and all excavation materials is the responsibility of the Contractor, including compliance with the requirements of all agencies having jurisdiction.

5.5.1 Pipe Zone

The pipe zone shall include the full width of trench from four inches below the bottom of

the pipe or conduit to a horizontal level 12 inches above the top of the pipe per Standard Detail SD-101.

5.5.2 Sheeting, Shoring and Bracing of Trenches

Trenches shall have sheeting, shoring, and bracing conforming to the latest Cal-OSHA requirements. Shoring plans must be prepared and stamped by a Professional Engineer registered in the State of California.

5.5.3 Imported Sand – Pipe Zone and Pipe Bedding

Imported sand used in the pipe zone and for the pipe bedding shall consist of natural or manufactured granular material, or a combination thereof, free of deleterious amounts of organic material, mica, loam clay, rocks and other substances not suitable for the purpose intended. Imported sand shall be graded such that 100% passes 3/8" sieve and 0 - 10% passes No. 200 sieve. Sand shall have a sand equivalent of not less than 50 per ASTM D2419.

5.5.4 Rock Fill for Foundation Stabilization

Rock fill shall be crushed or natural rock containing less than one percent asbestos by weight or volume.

5.5.5 Native Earth Backfill – Trench Zone

In the absence of stricter requirements, the material above the pipe zone may be native material that does not contain rocks larger than three inches and shall be so graded that at least 40 percent of the material passes a No. 4 sieve. The Contractor may use imported sand in the trench zone, provided there is no additional cost to the District.

5.5.6 Special Slurry Backfill

For pipelines which are laid in an already paved street, the backfill required above the pipe zone may be a one sack slurry mix in lieu of compacted soil backfill.

5.5.7 Asphalt Concrete Paving

Asphalt concrete paving shall conform to Class B-AR-4000 (for the Structural Section) and C2-AR-4000 (for the cap) as listed in the Standard Specifications for Public Works Construction Latest Edition, by APWA.

Within the rights-of-way of the State Department of Transportation, the Ventura County Public Works Agency Transportation Department, the City of Ojai, and the City of Ventura, asphalt concrete paving shall be in accordance with requirements and provisions of the permits issued by those agencies. Such requirements and provisions, where applicable, shall take precedence and supersede the provisions of these Specifications.

5.6 CONCRETE AND MORTAR WORK

Concrete work shall be in accordance with the Standard Specifications for Public Works Construction Latest Edition, by APWA.

Within the rights-of-way of the State Department of Transportation, the Ventura County Public Works Agency Transportation Department, the City of Ojai, and the City of Ventura, concrete and mortar work shall be in accordance with requirements and provisions of the permits issued by those agencies. Such requirements and provisions, where applicable, shall take precedence and supersede the provisions of these Specifications.

5.6.1 Design Criteria

Concrete for thrust blocks, pipe, and pump can encasement, and other unreinforced concrete, shall contain not less than five sacks of Portland cement per cubic yard and attain a strength not less than 2,000 psi at 28 days.

5.6.2 Cement Mortar Lining and Coating (CMLC).

Unless otherwise approved or as revised below, all steel pipe shall be mortar lined and coated in accordance with AWWA C205, which covers shop applied lining and coating, per main line pipe materials.

Ends of lining shall be left square and the lining holdback shall be as specified for the particular type of joint.

5.6.3 Concrete Admixtures

Concrete admixtures shall be as specified in the Contract Documents or shown on the Drawings.

Do not use any accelerating water-reducing admixture or any other type of admixture that contains chlorides or other corrosive elements in any concrete without prior District Representative approval.

To prevent segregation and improve workability, or to cause an increase in strength, a reduction in mixing water will be permitted when approved in writing by the District's Representative. Only admixtures which reduce shrinkage by at least 10 percent and are not lignin are permitted. Admixtures will not be permitted in a concrete mixture placed contiguous to steel water line piping and appurtenances.

5.6.4 Reinforcing Steel

Where specified, reinforcing bars shall be Deformed Billet-Steel Bars for Concrete Reinforcement, ASTM A615 unless otherwise noted.

5.6.5 Embedments

The Contractor shall furnish all embedments required for proper installation of accessories or equipment specified in the Contract Documents or shown on the Drawings.

5.6.6 Forms

Forms for exposed interior and exterior concrete shall be plastic coated, edge sealed plywood. All sharp edges shall be chamfered with 3/4-inch by 3/4-inch triangular fillets.

5.6.7 Curing Compound

Curing compound shall conform to ASTM C309.

5.7 PAINTING

This section covers the paint materials. "Painting" as it relates to construction is discussed in Section 6.15. Painting materials shall comply with AWWA D102.

Exterior surfaces of all buried metal (except bronze) shall receive two coats of Sanchem NO-OX-ID, 15 mils each.

The interior of valves, with the exception of bronze and working parts (see exceptions below), shall be coated with 100 percent solids, catalytically setting epoxy which is manufactured for use in the interior of potable water systems. The fusion method of coating 100 percent solid epoxy is acceptable. The two components shall be of different colors to aid in complete mixing. The epoxy lining shall be factory applied and field applications will not be allowed.

Exceptions to the above policy for interior coating require written District approval in advance of delivery to the job site.

5.7.1 Steel, cast iron and other bitumen coated metals

Above-ground facilities and/or facilities in vaults shall be primed in accordance with the Contract Documents and finish coats of Rust-oleum, or as approved for the particular installation. Table 10 shows the coating requirements for potable water facilities.

**Table 10
Coating Requirements for Potable Water Facilities**

Facility	Finish Coat
Line Valve Stack Cover	Rust-oleum Sunrise Red
Closed Valve Stack Cover (Zone Valve)	Rust-oleum Sunrise Red
Fire Hydrant Valves Stack Cover and Fire Hydrant Body	Rust-oleum Safety Yellow
Blow-off Valve Stack Cover	Rust-oleum Metallic Aluminum
By-Pass Valve Stack Cover	Rust-oleum Metallic Aluminum

Table 10
Coating Requirements for Potable Water Facilities

Facility	Finish Coat
Detector Check Meter Piping and Valves	Meter Piping – as determined by District Representative; Valves - Rust-oleum Safety Yellow
Master Meter Piping and Valves	Meter Piping – as determined by District Representative; Valves - Rust-oleum Metallic Aluminum
Combination Air Release Can	Rust-oleum Safety Yellow
Guard Post	Rust-oleum Metallic Aluminum
Bottom and Top of Lid(s)	Hot dipped Galvanized
Ladder	Rust-oleum Metallic Aluminum
Bolts and Nuts	Sanchem NO-OX-ID

5.8 SERVICE LINE MATERIALS AND FITTINGS

The materials covered in this section include the service saddle, service line pipe, corporation stop and angle meter stop inside the meter box. Where specific manufacturers' products are listed, it should be understood that other products which are equivalent may be used if approved in writing by the District. The minimum service line size is one inch.

Water meter types and manufacturers will be selected by the District. Table 11 shows requirements for service line materials and fittings.

Table 11
Service Line Materials and Fittings

Service Line	Meter Size	Corp Stop Inlet	Corp Stop Outlet	Mfr	Type
1-inch	¾- and 1-inch	MIP Thread	Compression or MIP Thread	Ford or Mueller	FB1100-4-Q-NL, F500-4NL, B-25028N, B-20013N
2-inch	1½- and 2-inch	MIP Thread	Compression or MIP Thread	Ford or Mueller	FB1100-6-Q-NL, FB1100-7-Q-NL B-25025N, B-25028N

5.8.1 Copper Pipe

Copper pipe material shall be used for all service lines from one-inch through two-inches. The pipe shall be Type K soft copper tubing for 1-inch service lines and Type K-

2 hard for 2-inch service lines, made in the USA. Solder fittings shall be soldered with solder containing no lead; instead, it shall be a blend of copper, phosphorous, and silver. Service lines are to receive backfill of imported sand within the pipe zone.

5.8.2 Service Saddles

These shall be of the double-strap type made of bronze with bronze nuts. The thread shall be female iron pipe thread. They shall be as shown in Table 12.

**Table 12
Approved Tapping Saddles**

Main Material	Manufacturer	Type
Ductile or AC	Ford	202B
Ductile or AC	Mueller	BR2B
PVC	Ford	202BS
PVC	Mueller	BR2S
Steel, Schedule 40 and Schedule 80	Ford	FC202
Steel	Forged Steel 3000#	Threadolet

5.8.3 Hot Tapping

Hot taps on steel mains must use reinforcement collars when the diameter of the branching pipe is less than half the main pipe diameter. When the branching pipe equals or exceeds half the pipe diameter, a full wrap saddle shall be used.

Hot taps of one-inch through two-inch on steel main must use a 3,000-pound steel coupling. Tapping sleeves must comply with AWWA C223. Approved tapping sleeves are Romac SST.

The effective shoulder width (W) of collars or wrappers from the inside surface of the steel riser to the outside edge of the collar or wrapper measured on the surface of the cylinder shall be not less than one-third nor more than one-half the inside diameter of the steel riser. The thickness of the collar or wrapper shall be not less than T as determined by:

$$T = \frac{(P_w)(ID\ cyl)(ID\ riser)}{36,000 (W)}$$

where P_w is the design class in pounds per square inch and other dimensions are in inches.

5.8.4 Abandonment of Water Service Lines

Where shown on the Drawings or directed by the Engineer, abandon existing water service lines, 2 inch and smaller, at the corporation stop while main line is pressurized. Where making abandonments at existing corporation stops, shut the corporation stop, remove the service line from the corporation stop and cap corporation stop with the appropriate threaded cap or plug, approved by District. If the water service line cannot

be removed without damaging the existing corporation stop and/or creating a leak, the water service line shall be cut off at the existing corporation stop and sealed with silver solder. Nut on the bottom of the existing corporation stop, if present, shall be completely tightened. If the existing corporation stop leaks when fully closed or after being tightened, the existing corporation stop shall be completely plugged as approved by the District.

Where shown on the Drawings or directed by the Engineer, abandon existing water service lines, 2 inch and smaller, at the corporation stop while main line is de-pressurized. Where making abandonments at existing corporation stops, remove the corporation stop, and plug the existing saddle with the appropriate threaded plug, approved by the District. If the corporation stop is directly tapped into the main, remove the existing corporation stop and seal opening with a full circle clamp, approved by District.

5.8.5 Corporation Stops

Corporation stops shall be bronze.

5.8.6 Angle Meter Stops

Angle meter stops shall be bronze. Table 13 shows the requirements for angle meter stops.

**Table 13
Angle Meter Stops**

Service Line	Meter Size	Angle Meter Stop	Inlet Side	Outlet Side	Mfr	Type
1-inch	¾- and 1-inch	MIP Thread	FIP Thread	Compression or MIP Thread	Ford or Mueller	KV-13-332-W-NL KV-13-444-W-NL H-14265N
2-inch	1½- and 2-inch	MIP Thread	FIP Thread or Compression	Compression or MIP Thread	Ford or Mueller	FV13-666-W-NL FV13-777-W-NL B-24276N

5.8.7 Angle Meter Stop Adapters

Angle Meter Stop Adapters shall be as shown in Table 14.

**Table 14
Angle Meter Stop Adapters**

Size	Inlet	Outlet	Manufacturer	Type
¾-inch	Compression	MIP Thread	Ford	C84-33-Q-NL
1-inch	Compression	MIP Thread	Ford	C84-44-Q-NL
1 ½ -inch	Compression	MIP Thread	Ford	C84-66-Q-NL
2-inch	Compression	MIP Thread	Ford	C84-77-Q-NL

5.8.8 [Customer Hand Valves](#)

Customer hand valves shall be bronze ball valves with a customer handle. The outlets are always female iron pipe threads. Table 15 shows the requirements for customer hand valves.

**Table 15
Customer Hand Valves**

Meter Size	Inlet	Outlet	Manufacturer	Type
3/4-inch	Meter Swivel	FIP	Ford	B13-332W-HB34S-NL
1-inch	Meter Swivel	FIP	Ford	B13-444W-HB34S-NL
1-1/2-inch	Flanged	FIP	Ford	BF13-666W-NL
2-inch	Flanged	FIP	Ford	BF13-777W-NL

5.8.9 [Meter Boxes](#)

Table 16 shows the meter box requirements for 3/4", 1", 1½", and 2" meters.

**Table 16
Meter Boxes**

Meter Size	Manufacturer	Box Model Number	Cover Model Number
5/8", 3/4" or 1"	Old Castle	FL12	FL12D
1½" or 2"	Old Castle	FL36	FL36D

For larger meter sizes and traffic-rated meter boxes, contact the District Representative.

Meter boxes shall be set as shown in Standard Detail SD-111. District crews will install the meter.

5.8.10 [Double Check Valves](#)

Double check valves shall be provided and installed per Standard Detail SD-110.

5.8.11 [Fire hydrants](#)

Fire hydrants shall be wet barrel type meeting AWWA C503 and have a six-inch flanged inlet with one 2½ -inch and one four-inch valved outlet with National Standard fire hose threads.

Fire hydrants at or near street intersections shall be located inside the intersection valving and located at the curb return. Fire hydrants located between intersections must be located on property lines. For typical installation refer to Standard Detail SD-109.

Other hydrant requirements are:

- The outlets shall be protected with plastic or metal caps attached to the hydrant head with a chain.
- Hydrant flanges shall contain six equally-spaced bolt holes for static pressures under 200 psi and eight equally-spaced bolt holes for static pressures greater than 200 psi.
- All hydrants shall be permanently marked with the manufacturer's name and the year of manufacture.
- Hydrant lateral shall be PVC as shown on Standard Detail SD-109.
- Hydrant valve shall be a six-inch valve with flange by mechanical joint for PVC pipe. The District Representative may require a break-off check-valve depending on site conditions.
- Painting shall be per Section 5.7 and 6.15 of these Standards.
- Spool shall be used between the bury/ell and fire hydrant. Spools generally are available in 30", 36", 42" and 48" lengths. An approved product is Tyler.
- Hydrant burys for PVC pipe shall be a six-inch inside diameter and made of cast iron conforming to ASTM A126. The burys shall be one piece with the top having a flange drilled with holes to receive the extension spool or hydrant. The bottom shall have a 90° bend end for meeting the horizontal pipe. In the event the hydrant lateral is PVC then the bury end shall be a mechanical joint fitting. Burys are generally available in 30", 36", 42" and 48" lengths. An approved product is "Tyler Hydrant Burys."

5.8.11.1 Bolts

Alloy steel break-off (shear) bolts shall be used to attach the fire hydrant to the extension spool. Buried bolts and nuts shall be hot dip galvanized coated with Sanchem NO-OX-ID per Section 5.7 herein.

5.8.11.2 Mains to Fire Hydrants

Separate lines used only for fire hydrants shall be a minimum of six inches in diameter. Actual size to be determined by the District Representative.

5.8.11.3 Approved Fire Hydrant Assemblies

Table 17 shows approved fire hydrant assemblies.

Table 17
Fire Hydrant Assemblies

Manufacturer	Classification	Model
Jones	Residential	4040
	Commercial	4060
	Industrial	4065
Clow	Residential	850
	Commercial	860
	Industrial	865

5.8.12 Combination Air Release Assemblies

For typical installation refer to combination air release assembly Standard Detail SD-105.

The combination air release assembly has the features of an air release valve and an air and vacuum valve. Both units shall be housed in a cast iron body and all internal parts such as the float, bushings, level pins, seat and baffle shall be either stainless steel or brass as furnished by the manufacturer. All assemblies shall be rated at 300 psi maximum operating pressure.

Air and vacuum valves are to be connected to the high point of the main lines. Air and vacuum valves at or near street intersections must be located inside the intersection valving where practical and located at the beginning or end of curb return. Air and vacuum valves located between intersections must be located on property lines.

Approved air and vacuum assemblies are as shown in Table 19.

Table 18
Air and Vacuum Valve Assemblies

Size	Valve No.
ARI	
1"	D040
2"	D040
Vent-O-Mat	
3"	Series RBX
4"	Series RBX
Crispin	
1"	UL10
2"	UL20
APCO	
1"	143C

Table 18
Air and Vacuum Valve Assemblies

Size	Valve No.
2"	145C

5.8.13 Blow-off Assemblies.

Blow-offs shall be wet barrel type meeting AWWA C503 and have a four-inch inlet. Blow-offs shall have one 2½ -inch valved outlet with National Standard fire hose threads. For typical installation refer to Standard Detail SD-106-108.

The outlet shall be protected with a cap attached to the hydrant head with a chain.

All blow-off valves shall be permanently marked with the manufacturer's name and the year of manufacture.

Separate lines used only for blow-offs shall be a minimum of four inches in diameter. Actual size to be determined by the District.

Blow-off valve shall be a four-inch flanged gate valve flange.

6 CONSTRUCTION

6.1 General Requirements

This section describes the use of materials and workmanship to be employed in construction of the water system. The developer/engineer shall prepare such general and special specifications as are necessary to define the nature and location of the work, contractual arrangements, payment for work and any other matters concerning the Owner or Contractor; these items are not discussed within the standards presented here.

In accordance with the provisions of California Business and Professions Code Section 7059, the District requires the Contractor be licensed in the State of California and possess a Class A or C-34 license.

The construction section is intended to highlight the features of construction which are deemed to be most significant. In any construction activity, the recommendations of the manufacturer of a product, especially where more stringent, should apply.

Specific references which are incorporated into this section include:

- AWWA C206 Field Welding of Steel Pipes.
- AWWA C600 Installation of Ductile Iron Mains and their Appurtenances
- AWWA C602 Cement Mortar Lining of Water Pipelines in Place – 4 in. and Larger
- AWWA C604 Installation of Buried Steel Water Pipe – 4 in. and Larger

- AWWA C605 Underground Installation of Polyvinyl Chloride (PVC) and Molecularly Oriented Polyvinyl Chloride (PVCO) Pressure Pipe and Fittings
- AWWA C900 Polyvinyl Chloride (PVC) Pressure Pipe, four inches through 12 inches.
- AWWA C905 Polyvinyl Chloride (PVC) Pressure Pipe, 14 inches through 36 inches.
- AWWA Manual M11 Steel Pipe - Design and Installation.
- AWWA Manual M17 Installation, Operation and Maintenance of Fire Hydrants.
- AWWA Manual M23 PVC Pipe - Design and Installation.

Section 5 of these Standards contains material descriptions. The Contractor should use that section along with this section and the respective Standard Details as a reference.

6.1.1 Protection/Operation of Existing Water System

A primary concern of the District is the protection and operation of the existing water system. No Contractor is allowed to operate any existing water valves or to cause a shutdown of any portion of the District's water system without prior approval from the District.

Following approval from the District, any operation of valves in a planned shutdown will be done by the District. Any planned shutdown shall be discussed at the preconstruction meeting and at least three weeks in advance of a planned shutdown. Shutdowns will only be allowed if no other reasonable alternative exists, such as the use of a hot-tap connection in lieu of a cut-in tee. When shutdowns are required in a part of the District's system, the District will evaluate whether the shutdown should be done during the day or at night. Contractor economics shall be weighed less heavily in the decision than the interruption and inconvenience to existing customers. Any shutdown shall involve a thorough notification plan for existing customers as well as the provision of a temporary highline, bottled water, water tanks, etc. where appropriate, at no expense to the District.

6.1.2 Quality of Materials.

Materials and equipment to be incorporated into the work shall be new and unused. In case a reference is not clear as to which of several available grades is desired, the highest quality material shall be used.

Contractor shall have at the job site or be able to supply upon request, shop drawings, and certified copies of factory or laboratory test reports showing the strength characteristics of any materials used in the work. For all reinforced concrete work, Contractor shall furnish in advance of placing concrete, the mix design and calculated concrete strength as prepared by the concrete supplier.

The Contractor's attention is called to the time required for obtaining certain materials and equipment to be furnished. It shall be the responsibility of the Contractor to

promptly place orders for items of extended delivery times.

6.1.3 Construction Water

All water used for construction shall be metered. The Contractor shall apply at the District's headquarters office for one or more construction meters. After receipt of a deposit amount, the District will install the meter at the fire hydrant location approved by the District. Upon request and approval by the District Representative, the District will move the hydrant meter to another location. The Contractor is not to move the construction meter(s). Charges for construction water are covered by the District's Rates and Regulations for Water Service. Unpaid invoices will result in removal of the construction meter.

6.1.4 Substitutions

Where articles or materials are specified by brand or trade name, alternate materials or articles equal to those specified may be approved provided the request for approval is in writing accompanied by supporting data and received in ample time to permit investigations without delaying the work. Unless substitutions have received prior approval, no deviation from the Standards is allowed.

6.1.5 Quality of Workmanship

All work will be done by persons experienced in the specific work, under competent supervision, and in a first class manner to the District's complete satisfaction.

6.1.6 Supervision and Superintendence

The Contractor shall designate and keep on the work a competent superintendent, who shall not be replaced without written notice to the District's Representative, at all times during its progress. The superintendent will be the Contractor's Representative at the site and shall have authority to act on behalf of the Contractor. All communications given to the superintendent shall be as binding as if given to the Contractor. During periods when the work is suspended, the Contractor shall make appropriate arrangements for any emergency work which may be required.

Whenever the superintendent is not present on any particular part of the work, the Owner's Representative may desire to inform the foreman or other worker in charge of the particular part of the work to whom the given information is relevant. Information so given shall be as binding as if given to the superintendent.

6.1.7 Defective Work

Any defective materials or workmanship which shall become evident within one year after acceptance of completed work shall be replaced or repaired without cost to the District. The District has the right to bring legal action to correct the deficiencies as well as to withhold exoneration of performance bonds.

6.1.8 District Inspection, Field Acceptance and Guarantee Period

Whether expressly indicated on the Drawings or not, all Contractors shall call the

Underground Service Alert prior to any excavation. Failure to do so shall not relieve the Contractor of any liability associated with disturbance/breakage of existing utilities. The District will inspect all pipe installation including appurtenant structures and trench backfill within the pipe zone. The Contractor must provide five working days' notice to the District Representative prior to the start of any work. Such notification will allow for scheduling a preconstruction meeting between interested parties. Failure to provide proper notification may delay the starting date since the District Representative may not be able to inspect the work and cannot accept any work for which inspection has not been arranged.

The District's Representative shall at all times have access to the work during construction to inspect the progress, workmanship, and materials used in the work.

Whenever the Contractor varies the normal period during which work or any portion of it is carried on each day, 48 hours' notice shall be given to the District's Representative so the Representative may be present to observe the work in progress. If the Contractor fails to give such notice, any work done in the absence of the District's Representative will be subject to rejection.

The Contractor shall give 48 hours' notice to the District's Representative in advance of backfilling or otherwise covering any part of the work so the District's Representative may observe such part of the work before it is concealed.

The observation, if any, by the District's Representative of the work shall not relieve the Contractor of any obligations and the primary responsibility for compliance with all District requirements and standards rests with the Contractor.

Defective work shall be made good, and materials and equipment furnished and work performed which is not in accordance with the Contract Documents may be rejected notwithstanding the fact such materials, equipment and work were previously observed by the District's Representative or that payment therefore was included in an estimate for payment.

Field acceptance is made by the District Representative and will not coincide with the date of the District Board of Director's acceptance of the work. The one-year guarantee period for all work shall begin as of District Board of Director's acceptance. Any defective work discovered during this period shall be repaired or replaced. A new one-year guarantee period will begin for such corrected work.

6.1.9 Public Relations.

The Contractor shall conduct its affairs in a manner which will lessen the disturbance to residents in the vicinity of the work. Working hours shall be 8:00 a.m. to 4:30 p.m., Monday through Friday, excluding District holidays, unless prior written approval is received from the District. For updated schedule of holidays contact the District Representative. Inspections requested by or made necessary as a result of the actions of the Contractor outside the normal working period or on Saturdays, Sundays, or

District holidays must be scheduled and approved in advance by the District. All costs for the required inspections outside the normal working period shall be the responsibility of the Contractor with payment agreed to by the Contractor in advance of the inspection at the rate established by the District.

The Contractor shall provide a minimum 48-hour written advance notice to the District Representative for all work anticipated outside the normal working period with payment agreed to by the Contractor in advance.

6.1.10 Sanitation

The Contractor shall provide and maintain enclosed toilets for the use of employees engaged in the work. These accommodations shall be maintained in a neat and sanitary condition.

6.1.11 Cleanup and Dust Control

Throughout all phases of construction, including suspension of work, and until final acceptance of the project, the Contractor shall keep the work site clean and free from rubbish and debris. The Contractor shall also abate dust nuisance by cleaning, sweeping and sprinkling with water, or other means as necessary. The use of water resulting in mud on public streets or District grounds will not be permitted as a substitute for sweeping or other methods. Their supply and application shall be at no expense to the District.

Materials and equipment shall be removed from the site as soon as they are no longer necessary; and upon completion of the work and before final inspection, the entire work site shall be cleared of equipment, unused materials and rubbish so as to present a satisfactory, clean and neat appearance.

Care shall be taken to prevent spillage on haul routes. Any such spillage shall be removed immediately and the area cleaned.

6.1.12 Observation of Work by Public Agencies

The Contractor is responsible for procuring, scheduling and coordinating all observations/inspections by Public Agencies as required by their respective permits and governing codes. The District's Representative shall be notified in writing, 48 hours in advance, of such scheduled inspection, and shall have the opportunity to be present during the inspection.

6.1.13 Safety

In accordance with generally accepted construction practices, the Contractor shall be solely and completely responsible for conditions of the jobsite, including safety of all persons and property during performance of the work, and the Contractor shall fully comply with all state, federal and other laws, rules, regulations, and orders relating to safety of the public and workers.

The right of the District's Representative to conduct construction review or observation

of the Contractor's performance will not include review or observation of the adequacy of the Contractor's safety measures in, on, or near the construction site.

6.1.14 Traffic Control Devices and Signs

Within the rights-of-way of the State Department of Transportation, the Ventura County Public Works Agency Transportation Department, the City of Ojai, and the City of Ventura, construction shall be in accordance with requirements and provisions of the permits issued by those agencies. Such requirements and provisions, where applicable, shall take precedence and supersede the provisions of these Specifications.

Construction signing, striping, barricades and other traffic control devices used for handling traffic and public convenience shall conform to the latest edition of the State of California, Department of Transportation, "Manual of Traffic Controls for Construction and Maintenance Work Zones" at no expense to the District. Signs shall be illuminated or reflectorized when they are used during hours of darkness. Provide cones, pylons, barricades or posts used in the diversion of traffic with flashers or other illumination if in place during hours of darkness at no expense to the District.

Maintain a 24-hour emergency service to remove, install, relocate and maintain warning devices and furnish to the authority having jurisdiction names and telephone numbers of three persons responsible for this emergency service. In the event these persons do not promptly respond or the authority having jurisdiction deems it necessary to call out other forces to accomplish emergency service, the Contractor will be held responsible for the cost of such emergency service.

6.2 PERMITS

The following permits may be required of the Contractor:

6.2.1 Encroachment.

Within the rights-of-way of the State Department of Transportation, the Ventura County Public Works Agency Transportation Department, the City of Ojai, and the City of Ventura, encroachment shall be in accordance with requirements and provisions of the permits issued by those agencies. Such requirements and provisions, where applicable, shall take precedence and supersede the provisions of these Specifications.

All approvals must be obtained from local agencies prior to mobilizing/beginning of work, e.g. approved encroachment permit.

6.2.2 Easements.

Contractor shall comply with any terms, conditions, limitations, or other provision contained in any temporary or permanent easements issued to the District.

6.3 UTILITIES AND EXISTING FACILITIES

6.3.1 Utilities and Existing Facilities

Whether expressly indicated on the Drawings or not, all Contractors shall call the

Underground Service Alert prior to any construction of pipelines. Failure to do so shall not relieve the Contractor of any liability associated with disturbance/breakage of existing utilities.

In case it shall be necessary to remove and or relocate any such utilities, facilities or any portions thereof, the Contractor shall notify the District and authorized agent of the owner of the utility and/or facility so affected. The Contractor shall not interfere with said utility and/or facility structures until disposition of the obstruction to the work is determined and/or notice to relocate or remove is given by the District or authorized agent of the owner of the utility and/or facility so affected.

Any existing utility or facility, shown or not shown on the Drawings, inadvertently damaged during excavation shall be repaired by the Contractor at no expense to the District.

The fact that any underground utility and/or facility is not shown on the Drawings shall not relieve the Contractor's responsibility to comply with these standards. It shall be the Contractor's responsibility to ascertain, prior to commencing work, the existence of any underground utilities or facilities which may be subject to damage by reason of Contractor's operations.

6.3.2 Separation Requirements for Water and Wastewater Lines

California Waterworks Standard (Title 22, Chapter 16, Article 4, Section 64572) for separation of water and wastewater lines shall be followed. In the event special permission is needed, it shall be the Owner's responsibility to attain such written approval from the Division of Drinking Water and the District prior to construction.

6.4 EARTHWORK/CLEARING AND GRUBBING

6.4.1 General

Earthwork shall include all necessary clearing, grubbing, grading, excavation, backfilling, compaction and cleaning up debris.

Included is controlling water, bracing excavations, stabilizing subgrade, protecting existing structures and facilities and such supplementary operations as are necessary to properly complete the entire work indicated or specified.

6.4.2 Obstructions

The Contractor's attention is directed to the possible existence of pipe and other underground improvements which may or may not be shown on the Drawings. The Contractor shall preserve and protect any such improvements whether shown on the Drawings or not. Where it is necessary to remove and replace or to relocate such improvements in order to prosecute the work, they shall be removed, maintained and permanently replaced by the Contractor.

6.4.3 Oak Tree Ordinance

The Owner and the Contractor must be aware of local oak tree ordinances which govern the protection, trimming, and removal of oak trees, as well as the limits of construction around oak trees. In general, any work under or within the protected zone of an oak tree may be subject to special requirements, with which the Owner and/or Contractor must comply.

6.4.4 Working Area

Except for specified off-site construction, all earthwork shall be confined strictly within site property lines or limits described in the Contract Documents and/or shown on the Drawings.

6.4.5 Clearing and Grubbing

All vegetation, such as roots, brush, heavy sods, heavy growth of grass and all decayed vegetable matter, rubbish and other unsuitable material within the area of the work shall be stripped or otherwise removed prior to starting excavation and backfill.

6.4.6 Grading and Stockpiling

The Contractor shall control grading in a manner to prevent water running into excavations. Obstruction of surface drainage shall be avoided and means shall be provided whereby stormwater can flow uninterrupted in existing gutters, other surface drains, or temporary drains. Material for backfill or for protection of excavation in public roads from surface drainage shall be neatly placed and kept shaped so as to cause the least possible interference with public travel. Free access must be provided to all fire hydrants, water valves, meters, and private drives.

6.4.7 Imported Backfill Material

Whenever the excavated material is not suitable for backfill, the Contractor shall furnish suitable imported backfill material.

6.4.8 Relative Compaction

Relative compaction specified herein shall be a percentage of the maximum density at optimum moisture content as determined by AASHTO Test No. T180-57 Modified. Unless otherwise specified, the relative compaction for earthwork in open fields shall be 90%. In populated areas and in public and private roads and driveways the relative compaction shall be minimum 90% in the pipe zone and 95% in the trench zone.

6.4.9 Compaction Tests

Compaction tests for Owner-installed facilities will be made at no cost to the District by an approved laboratory in accordance with ASTM D1557 or better. The number of tests and their location and depth shall be determined by the District's Representative. The Contractor shall make all necessary excavations for compaction tests as directed by the District's Representative and shall refill and recompact these excavations to the densities as specified herein.

For District capital projects, the District will retain a geotechnical firm to perform

compaction testing. If the initial compaction test does not meet the specifications, the Contractor shall be billed for subsequent compaction tests until the specifications are met.

In all cases, compaction test results shall be submitted in writing to the District Representative prior to testing for pipe and joint leakage.

6.4.10 Correction of Faulty Grades

Where excavation is inadvertently carried below subgrade and/or foundation elevations, it shall be rectified by backfilling with approved sand, compacted to structural standards and/or one sack slurry as directed by the District's Representative, all at the expense of the Contractor.

6.4.11 Soil Sterilant

The Contractor shall treat the finished subgrade of specified areas with an approved soil sterilant. All paved embankments, walkways, drainage structures, parking, and road areas require soil sterilant. The sterilant shall be applied in accordance with the manufacturer's directions and local environmental regulations.

6.4.12 Final Clean-up

After backfill has been completed, the site shall be dressed smooth and left in a neat and presentable condition, free of all cleared vegetation, rubbish and other construction wastes.

6.4.13 Seeding

The Contractor is required to scarify and seed the ground at locations along the pipeline where the native vegetation has been destroyed by construction operations and at other areas where seeding is determined to be necessary by the District's Representative. The areas shall be seeded with a District-approved mixture.

6.5 EXCAVATION AND TRENCHING

6.5.1 Safety Precautions

All excavations shall be performed, protected and supported as required for safety and in the manner set forth in accordance to the latest rules, orders and regulations prescribed by the State of California Department of Industrial Relations, Division of Industrial Safety "Construction Safety Orders."

Shoring plans must be prepared and stamped by a Civil Engineer registered in the State of California, whose license is currently in effect.

6.5.2 Alignment and Grades.

Trench depth shall be adequate to accommodate the pipe and its foundation at the profile shown on the Drawings. In the absence of such profile grade, the top of pipe grade shall be located three (3) feet below the existing street grade or existing ground. The measurement of the depth shall be at the trench centerline.

When the natural ground above the pipeline trench is over excavated and/or the pipeline is to be placed in new excavation, excavation material shall be placed and compacted to an elevation of not less than three feet above the top of pipe prior to trench excavation.

6.5.3 Foundation in Poor Soil

Where rock excavation is required, the rock shall be excavated to a minimum over depth of six (6) inches below the trench depths indicated on the Drawings or in the Contract Documents. Overdepths in the rock excavation and unauthorized overdepths shall be backfilled with the same material as the bedding zone. Whenever wet or otherwise unstable soil incapable of properly supporting the pipe as determined by the District Representative is encountered in the bottom of the trench, such soil shall be removed to the depth required and the trench backfilled to the proper grade with an appropriate material between a course sand and a crushed rock to provide a stable foundation.

The necessity of replacing unsuitable material at depths of more than two feet below bottom of pipe grade will be determined by the District's Representative. If the necessity for such additional removal and replacement was occasioned by an act or failure to act on the part of the Contractor, it shall be rectified by backfilling with approved sand compacted to structural standards and/or one sack slurry as directed by the District's Representative.

6.5.4 Trench Width

The width of the trench within the pipe zone shall be such that the clear space between the barrel of the pipe and the trench wall complies with the Standard Detail SD-101. In general, the widths shown in Table 19 shall be adhered to.

Table 19 Trench Widths

Nominal Diameter	Trench Width	
	Minimum	Maximum
6" - 12"	O.D. + 6"	O.D. + 9"
14" - 30"	O.D. + 9"	O.D. + 12"

Trench widths in excess of those shown may be as wide as necessary if for the explicit purpose of installing sheeting and bracing during the performance of the work.

6.5.5 Pipe Subgrade

The trench bottom shall have a flat or semi-circular cross section. The bottom of the trench shall be graded and prepared to provide a firm and uniform bearing throughout the entire length of each joint except for required "bell holes" at joints.

Foundations in poor soil where rock and soft spongy and deleterious material exists shall be removed.

6.5.6 Dewatering

The Contractor shall comply with the requirements of the Los Angeles Regional Water Quality Control Board Order No. R4-2013-005, General NPDES Permit No. CAG994004 Waste Discharge Requirements for Discharge of Groundwater from Construction and Project Dewatering to Surface Waters in Coastal Watersheds of Los Angeles and Ventura Counties, or most recent General Permit.

The Contractor shall provide and maintain at all times during construction ample means and devices with which to promptly remove and properly dispose of all water from any source entering the excavation or other parts of the work.

To ensure a firm, unyielding excavation and preservation of the final line and grade of the bottom of excavation, dewatering shall be continuous until such times as water can be allowed to rise.

The Contractor shall dispose of the water from the work in a suitable manner without damage to adjacent property. No water shall be drained into work built or under construction without prior consent of the District's Representative. Water shall be disposed in such a manner as not to be a menace to the public health.

6.6 **PIPE BEDDING AND LAYING FOR PVC, DI, AND STEEL PIPE**

6.6.1 General

This portion of the work includes the furnishing and installation of all materials and their proper assembly to result in a first class waterline installation true to line and grade and free from leaks, cracks and obstructions.

Do not lay pipe without giving the District Representative due notice to inspect the bedding.

All pipe 24 inches or greater in diameter shall be braced and studded to prevent damage during shipment. Any damaged pipe or fittings delivered and unloaded at trench side shall be removed by the Contractor from the work site.

For steel and ductile iron pipe, the off-loading of the pipe as well as placement in the trench shall be handled with straps. Chains or bare cinch or choker type cables shall not be used. The slings shall be sufficient width to prevent damage to the lining or coating. On 20-foot lengths of pipe or longer, two straps must be used.

The approved water pipeline design is based upon a proper combination of pipe strength and pipe support. No acceptance will be given unless the work of trenching, bedding, laying, backfilling and compaction is conscientiously done in accordance with the

procedures outlined in these Standards and the Contract Documents.

Grades shall be transferred from surveyor's reference set points based on approved construction plan and grade. Each length of pipe shall be laid on bedding as specified and shall have full bearing for its entire length between bell holes excavated in said bedding material to allow for unobstructed assembly of all joints. No wedging or blocking with wood or soil to support the pipe is permitted. Under no circumstances will a Contractor be allowed to dump backfill materials on top of a pipe which is not continuously supported in its final grade position.

Pipe shall not be laid when the District Representative determines the condition of the trench is unsuitable. As the work progresses, the interior of the waterline shall be cleared of all dirt and superfluous materials of every description. Trenches shall be kept free from water until sufficient backfill has been applied to keep the pipe in place. At times when work is not in progress, open ends of pipe and fittings shall be securely closed to the satisfaction of the District Representative so trench water, earth or other substance shall not enter the pipe or fittings. Pipe or fittings damaged during assembly shall be removed and replaced.

6.6.2 Pipe Indicator Tape

During the backfilling process, all water mains, service lines, and system appurtenances shall have pipe indicator tape installed continuously throughout their length at 12 inches above the pipe. At tees, tape ends, etc., the warning tape shall be tied together (spliced) with knot to create a continuous warning tape throughout the length of the pipeline and associated branch lines, appurtenances, etc.

6.6.3 Pipe Laying for PVC Pipe C900 and C905

Because it is a plastic product, the pipe should be covered with an opaque material if it is to be stored outside for a prolonged period of time (more than 45 days.)

Gasket lubricants shall be non-toxic and water soluble specially prepared for use in potable water systems.

In obtaining a square end cut, a PVC pipe cutter is recommended, but conventional fine-tooth hand or power saws may be used.

Field beveling of pipe ends after cutting can be done with special beveling tools or with such items as rasps.

The minimum short length of pipe shall be two feet and must meet the requirements of DR18 and DR14. The use of short pieces must be approved in advance by the District Representative.

6.6.3.1 Trench Grade Sheets

Prior to laying pipe, trench grade sheets must be submitted to the District's Representative with identification of horizontal and vertical angles and appurtenances.

Stationing and elevation shall be at 25- foot intervals and on all angles and appurtenances. Elevation shall consist of top of pipe and finished surface at these points.

6.6.3.2 Lowering of Pipe into Trench.

Pipe shall not be lowered into the trench until the pipe bedding has been brought to grade.

6.6.3.3 Pipe Deflection

The pipe joint shall not be deflected either vertically or horizontally beyond the limits recommended by the manufacturer. Table 20 shows the minimum curve radii for C900 and C905 pipe.

Table 20 – Pipe Layout for Curved Alignment

C900 Pipe Diameter	Minimum Curve Radius
4 inch	100 feet
6 inch	150 feet
8 inch	200 feet
10 inch	250 feet
12 inch	300 feet
C905 Pipe Diameter	Minimum Curve Radius
14-36 inch	764 feet

Special design is required for short curve radius.

Pipe deflection by the use of staking or any mechanical means is not permitted under any circumstances.

6.6.3.4 Locating Wire

Twelve gauge blue insulated copper wire shall be provided in the pipe zone directly on top of the pipe centerline. Copper wire shall be periodically wrapped or taped to the water pipe at intervals of five feet apart along the barrel by means of short strips of adhesive tape. Wire shall be continuous between successive valve boxes (including air and vacuum and valve boxes associated with fire hydrants and blow-off assemblies.)

The Contractor will perform all required tests to assure the continuity of the copper wire.

6.6.4 Pipe Laying For Steel Pipe

6.6.4.1 Shop Drawings

Shop drawings of all pipe and fittings shall be submitted to the District’s Representative

for approval prior to fabrication of the pipe and fittings. Pipe lay sheets shall be included, consisting of drawings of lay, identification of joints, horizontal and vertical angles, and appurtenances. Stationing and elevation shall be shown on all joints, angles, and appurtenances. Elevation shall consist of top of pipe and finished surface at these points. Fabricated angles shall meet the requirements of AWWA C208. Except for butt strap closures, field fabricated fittings are not permitted unless approved by the District. Format for shop drawings and lay sheets may be obtained from the District Representative. Such approval is an additional precaution against errors and is not to be construed as relieving the Contractor of the full responsibility for the accuracy of the shop drawings.

6.6.4.2 Trench Grade Sheets

Prior to laying pipe, trench grade sheets must be submitted to the District's Representative with identification of horizontal and vertical angles and appurtenances. Stationing and elevation shall be shown on all joints, angles and appurtenances. Elevation shall consist of top of pipe and finished surface at these points.

6.6.4.3 Rubber Ring Joints

Joining the pipe is similar to that for PVC and DI pipe with exceptions noted under Section 6.6.3.9 Welded Joints and Section 6.6.3.12 Electrically Bonded Connections.

6.6.4.4 Flanged Joints

The inherent problem with flanges is they are rigid and do not provide flexibility. Three keys to their installation are (1) uniform tightening of the bolts; (2) do not mate steel raised face flanges with flat face cast iron flanges or vice versa and (3) prevention of bending or torsional strains. Proper anchorage is important to meet the latter objective.

All flanges, bolts and nuts must be covered with Sanchem NO-OX-ID per Section 5.7 of these Standards.

6.6.4.5 Flexible Coupling Joints

Joints shall be completed in the trench after the pipe is laid to the alignment and grade shown on the Drawings. Each pipe, for a distance of six to eight inches back from the end, shall be thoroughly cleaned to remove oil, dirt, loose scale, rust, and other foreign matter. Flanges, gaskets, and sleeves shall then be assembled on the pipe ends in accordance with the manufacturer's recommendations. Coupling sleeves shall be accurately centered over the pipe ends and one pipe end shall touch the coupling sleeve centering stop if the coupling sleeve is so equipped. Bolts and nuts must be covered with Sanchem NO-OX-ID per Section 5.7 of these Specifications.

6.6.4.6 Lowering of pipe and accessories into trench

Pipe shall not be lowered into the trench until the pipe bed has been brought to grade. The sealing surfaces of all materials shall be kept clean during installation.

When pipe laying is not in progress, the open ends of installed pipe shall be closed to prevent entrance of trench water or other substances into the line.

The pipe joint shall not be deflected either vertically or horizontally beyond the limits recommended by the manufacturer.

6.6.4.7 Mortar Lining of the Interior Joints

When the section has been laid in place, the joint shall be finished by pulling a rubber ball, or the equivalent, through the joint to finish it off smooth with the inside surface of the lining (swabbing.)

The Contractor must obtain a Confined Space Permit prior to mortar lining the interior joints when the pipe is 24-inches or larger.

No pipe shall be filled with water until at least 24 hours after the joints have been mortared.

6.6.4.8 Welded Joints

Field welding of joints shall be in accordance with AWWA C206.

No welded joint shall be backfilled until it has been inspected by the District Representative. Sufficient trench space shall be left open in the vicinity of each joint to permit visual inspection around the entire joint.

All welding shall be done by experienced welders qualified in accordance with the standards of the AWS and certified per ASME Section IX. Welding electrodes shall comply with the requirements of ASTM Specification A233. Welding procedures shall meet qualifications of AWS Standard D10.9 Qualification of Welding Procedures and Welders for Piping and Tubing.

Welds shall be applied by means of continuous stringer beads. Each bead shall be thoroughly cleaned and descaled before the succeeding bead is applied. The metal shall be deposited in successive layers and the minimum number of passes or beads in the completed weld shall be as shown in Table 21.

Table 21 – Welding for Steel Pipe

Steel Cylinder Thickness (inches)	Fillet Weld Minimum Number of Passes
Smaller than 3/16	1
3/16 and 1/4	2
5/16 and 3/8	3

In all welding, undercutting of the base metal adjoining the weld is a defect and shall be repaired. Overlapping or burning back the inside or outside corner during the application of a fillet weld is not permitted. The finished fillet weld must be free of grooves, deep valleys or ridges and contain no abrupt changes in section at the toe.

Lap or fillet welds shall have legs of equal size except when specified otherwise and they shall have a throat profile that is straight to slightly convex. In no case is a throat

with a concave surface acceptable.

After the joints are welded, each joint shall be grouted with cement mortar in the same manner as specified for mortar lining of interior joints.

6.6.4.9 Butt Strap Closure Joints

Butt strap closure joints shall be completed in the trench after the pipe is laid to the alignment and grade shown on the Drawings.

They shall be field welded to the outside of the pipe along both edges by full circumferential fillet welds. The interior of butt strap joints shall be grouted with cement mortar as specified in Section 6.6.3.8 for mortar lining of interior joints.

A ½-standard five-inch pipe coupling shall be welded to the top section of the butt strap to permit access for mortar lining the inside of the joint. The coupling shall be closed with a five-inch solid steel plug welded to the coupling.

The exterior of butt strap joints shall be wrapped with mesh wire and completely covered with mortar equal to the thickness of the existing coating.

Except for butt strap closures, field fabricated fittings and welded butt joints are not permitted, unless approved by the District Representative.

6.6.4.10 Mortar Coating of Exterior

Grout shall be composed of one part Type II cement to not more than two parts sand thoroughly mixed with water to the consistency of thick cream. Sand gradation shall conform to the requirements of ASTM C33 except that 100 percent shall pass the No. 16 sieve.

The joints shall be coated with cement-mortar, retained by suitable bands or diapers so as to bridge the joint and retain the grout without leakage. The diaper shall be made of heavy duty sail cloth of sufficiently close weave to prevent cement loss from the mortar. The fabric shall be hemmed on each edge and shall contain a metal strap within each hem sufficiently longer than the circumference of the pipe to allow a secure attachment of the diaper to the pipe. The diaper width will depend on pipe size and design and shall be the width recommended by the manufacturer. The diapers shall be Mar-Mac fabric diapers or approved equal.

The grout space, prior to filling, shall be flushed with water so the surface of the joint to be in contact with the grout will be thoroughly moistened when the grout is poured. The joint shall be filled with grout by pouring from one side only, and shall be rodded with a wire or other flexible rod or vibrated so the grout completely fills the joint recess by moving down one side of the pipe, around the bottom of the pipe, and up the opposite side. Pouring and rodding the grout shall be continued to allow completion of the filling of the entire joint recess in one operation. Care shall be taken to leave no unfilled space. The exposed portion of the grout at the top of the pipe shall be coated with a sealing

compound or covered with burlap or moist earth.

6.6.4.11 Electrically Bonded Connections

Jumper bond connections shall be welded on all underground connections where sections of steel pipe are joined by means of rubber rings.

The Contractor will make electrical and mechanical tests to determine that each joint between sections of pipe is satisfactorily bonded. The Contractor will then perform all additional work required to assure the pipeline is electrically continuous.

6.6.5 Pipe Laying for Ductile Iron Pipe

Ductile iron pipe shall be laid in accordance with manufacturer instructions and in general compliance with the applicable procedures as listed for PVC and steel pipe. Where specified, the District may request a specification for such installation practices.

Tapping of the pipeline for services is not allowed.

6.7 BACKFILL AND COMPACTION FOR PVC, DI AND STEEL PIPE

6.7.1 General

Backfill and compaction will be as listed in the Standard Specification for Public Works Construction Latest Edition, by APWA/AGC.

Within the rights-of-way of the State Department of Transportation, the Ventura County Public Works Agency Transportation Department, the City of Ojai, and the City of Ventura, backfill and compaction shall be in accordance with requirements and provisions of the permits issued by those agencies. Such requirements and provisions, where applicable, shall take precedence and supersede the provisions of these Specifications.

There are several distinct zones to be considered in the backfilling procedure as shown in Standard Detail SD-101.

In all cases, the filling of trenches shall be subject to approval by the District Representative and/or City or County Public Works Inspector who shall have full authority to order compaction tests to demonstrate the actual backfill density.

6.7.2 Backfilling Pipe Zone

Sand as specified in Section 5.6.3 of these Standards must be used and shall be placed in the pipe zone with particular attention to getting material to the underside of the pipe and fittings to provide a firm support along the full length of the pipe. Care shall be exercised in backfilling to prevent damage to the pipe or coating, as applicable.

6.7.3 Jetting Method in the Pipe Zone

Jetting with water to consolidate the sand in the pipe zone is acceptable when foundation soil provides adequate drainage and jetting is approved by District

Representative.

Acceptability of backfill in the pipe zone will be determined primarily by visual inspection and probing by the District Representative to determine that no voids exist in the backfill. The backfill within the pipe zone shall be per Standard Detail SD-101.

6.7.4 Backfilling Above Pipe Zone

Testing for pipe and joint leakage will be done after consolidation of the backfill to the top of the base zone and after service lines are installed to the property lines.

Contractor shall assume the responsibility of removal and replacement of backfill necessary for correction of defective conditions revealed by testing at no expense to the District.

In traffic areas within public rights-of-way where pavement is to be replaced, the City or County requirements may call for a cement sand slurry mixture to be used for trench backfill at no expense to the District.

Standard Detail SD-101 shows the District's trench requirements within the paved right-of-way.

6.7.5 Compaction Tests

All required excavations and tests for private Owner-installed facilities will be performed at no expense to the District. Tests shall be performed in accordance to ASTM D1557 by an approved geology laboratory.

The Contractor shall make all necessary excavations for compaction tests. The number of tests and their location and depth shall be determined by the District's Representative and/or a Representative of those agencies where construction is within their rights-of-way.

Compaction test results shall be submitted in writing to the District inspector prior to testing for pipe and joint leakage.

6.8 THRUST BLOCKS AND ANCHOR BLOCKS

Do not place concrete without giving the District's inspector 48 hours' notice.

6.8.1 Concrete Thrust and Anchor Blocks

Concrete thrust and anchor blocks shall be placed as required and shall consist of Portland cement concrete containing not less than five sacks of cement per cubic yard and shall conform to the applicable provisions of the Standard Specifications for Portland Cement Concrete. Concrete thrust and anchor blocks shall be placed between the undisturbed ground and the fittings to be anchored. The concrete shall be placed so pipe joints and fittings are accessible for repair. All concrete supports shall be allowed to cure for at least five days prior to filling the supported pipe with water or per special design provisions.

Quantity of concrete and the area of bearings on the pipe and undisturbed soil shall be as shown on the Drawings and per Standard Detail SD-102.

6.9 RESURFACING AND RESTORATION

Resurfacing and restoration will must comply with the Standard Specifications for Public Works Construction Latest Edition by APWA.

Within the rights-of-way of the State Department of Transportation, the Ventura County Public Works Agency Transportation Department, the City of Ojai, and the City of Ventura, resurfacing and restoration shall be in accordance with requirements and provisions of the permits issued by those agencies. Such requirements and provisions, where applicable, shall take precedence and supersede the provisions of the Specifications.

Substructures removed or damaged on public or private property shall be restored or replaced unless such structures are designated on Drawings "to be abandoned." Such structures include, but are not limited to: trees, bushes, plantings, ground cover, mail boxes, fences, and sprinkler systems.

Any temporary paving, barricades or special provisions required by public agencies shall be furnished at no expense to the District.

6.10 HOT TAPPING

Each new service shall have its own service line unless prior approval is received from the District Representative.

Hot tapping shall only be done in the presence of the District Representative. The tapping mechanism shall be as recommended by the tapping manufacturer.

Hot taps on steel mains must use reinforcement collars when the diameter of the branching pipe is less than half the main pipe diameter. When the branching pipe equals or exceeds half the pipe diameter, a full wrap saddle shall be used.

Hot taps of one-inch through two-inch must use a reinforcement collar and a 3,000-pound steel coupling.

6.10.1 Hot Tapping Contractors

Contractor must adhere to approved District tapping standards. No tapping shall be performed on steel cylinder pipe where the horizontal or spiral weld of the pipe will be in contact with any part of the nozzle or collar per Standard Detail SD-111.

Approved hot tapping Contractors for District-owned water systems 3-inches and larger are:

- Koppl Company, Inc.

Contractors who wish to perform 1-inch or 2-inch hot taps must provide proof of experience and references and receive prior District approval to perform hot-tapping.

6.11 SERVICE CONNECTIONS AND SERVICE LINES

As shown on Standard Details SD-111 and SD-112, service connections to the main where copper tubing is used for the service line shall be made at 20° above horizontal (springline.)

Water service laterals at intersections shall be located outside of the intersection valving whenever possible.

Service lines shall be one continuous length "snaked" within the trench to allow for expansion or contraction.

6.11.1 Service Taps

In no case shall a service tap be made in a main closer than two feet from a joint or fitting. Service taps shall not be less than two feet apart on PVC main, and no less than 18 inches apart on steel pipe mains. Service taps shall be located opposite the meter locations so the service laterals will be perpendicular to the water main and street centerline. Service tap locations varying more than five feet from the perpendicular must be approved by the District's Representative prior to installation. Unless otherwise noted on the Drawings, service taps shall be located so the water service lateral is parallel to and 10 feet from the sewer lateral serving the same property.

6.11.2 Dielectric Connections

Dielectric connections shall be provided where dissimilar metals are joined and shall conform to details shown on the Drawings or in the Contract Documents.

6.11.3 Earthwork

Earthwork shall conform to Standard Detail SD-111.

6.12 INSTALLATION OF VALVES AND FITTINGS

Valves and fittings shall be installed at the locations and grades shown on the Drawings. The following items comprise a partial check list:

- All line valves at intersections shall be located as close as possible to the beginning of curb return and/or end of curb return.
- Water distribution mains shall have valves spaced no greater than 1,000 feet apart or as shown on the Drawings.
- At water main intersections, each branch shall be valved. Where relatively short blocks separate water main intersections, one of the two valves between the water main intersections may be eliminated.
- All valves and appurtenances at depths greater than eight feet require special design and District approval.
- Valve restraints shall be used when installing mechanical joint valves

- below ground.
- When placing thrust blocks around a fitting, the concrete must be around the fitting and not the joint.

6.13 INSTALLATION OF FIRE HYDRANT ASSEMBLIES

Fire hydrant assemblies are to be installed in accordance with the general instructions contained in AWWA C600 and AWWA Manual No. M17 and Standard Detail SD-109.

The setback from the curb face must be per Standard Detail SD-109, whether the fire hydrant is on a public street or within a private street.

Fire hydrants at or near street intersections shall be located inside the intersection valving and located at the beginning of curb return or end of curb return. Fire hydrants located between intersections must be located on property lines.

The fire hydrant shall be positioned so the bolts between the extension piece and the hydrant are accessible, as shown on Standard Detail SD-109, except the distance from the ground to the bolts shall be three inches.

Painting shall be per Sections 5.7 and 6.15 of these Standards with all metal surfaces above ground being painted.

6.14 INSTALLATION OF METER BOXES

Specific installation details are shown on Standard Details SD-111 and SD-112. The District will select the meter type and install the meter after proper arrangements have been made.

6.15 PAINTING

Paints shall be delivered to the jobsite in original cans or packages bearing the brand name and the manufacturer's name.

Paints specified shall be used unless written District approval to use other products is obtained in advance.

Manufacturer's recommended time between coats will be used as a guide as to when the next coat of paint may be applied.

The Contractor shall notify the District Representative after surface preparation and after the application of each successive coat of paint.

Surfaces to be painted shall first be thoroughly cleaned to remove dirt, loose scale, rust, oil, grease and/or other foreign matter immediately prior to painting.

After cleaning, metal surfaces shall receive two primer coats of a minimum film thickness of 15 millimeters each or equivalent conditioning or seal coats and two finish coats of two millimeter thickness each.

6.16 ABANDONMENT

The Contractor shall remove and dispose of or abandon in place existing pipelines, structures, or appurtenances as shown on the Drawings.

Abandonment of all water mains and appurtenances shall be approved by the District prior to any such work.

Water lines to be abandoned shall be pumped full with a two-sack sand slurry mix and a blind flange shall be installed on each end, unless otherwise shown on the Drawings. Each end shall be encased with a minimum of six inches of concrete per Section 5.8.4. Said concrete shall thoroughly cover all exposed metal.

Structures and appurtenances associated with lines to be abandoned shall be removed by the Contractor.

All materials and appurtenances determined by the District Representative to be salvageable are District property and shall be delivered by the Contractor to the District warehouse at no cost to the District.

6.17 HYDROSTATIC TESTING OF WATER MAINS

All completed waterlines, as well as the service lines and appurtenant structures, will be tested by and at the expense of the Contractor in the District Representative's presence prior to field acceptance of the work. The Contractor must correct all defects in workmanship or materials which become evident by inspection or testing at any time during the work. Testing will be done after the complete installation and compaction of all underground utilities, except as modified below.

6.17.1 General Requirements

Pipe and all appurtenances shall be subjected to a four-hour hydrostatic pressure test. This test shall consist of applying to the pipeline a pressure of 50 psi in excess of the designated working class of pipe. Pressure tests shall not be performed until backfill and compaction is completed to subgrade per Section 6.4. Re-tests shall be conducted following "disturbances" of the pipe zone pipeline or appurtenances at the discretion of the District Representative.

The maximum length of pipe to be included in any one test shall be no more than 2,500 feet or the distance between valves, whichever is greater. The Contractor shall provide suitable test bulkheads, blocking and fittings to permit such sectionalizing.

6.17.2 Flushing

Before conducting hydrostatic tests, flush pipes with water to remove dirt and debris. Maintain a flushing velocity of at least 2.5 feet per second (fps) for water testing. Flush pipes for time period as given by the formula:

$$T = \frac{2L}{2.5}$$

in which:

T = flushing time (seconds)

L = pipe length (feet)

For pipelines 24 inches or larger in diameter, acceptable alternatives to flushing are use of high-pressure water jet, sweeping, or scrubbing. Water, sediment, dirt, and foreign material accumulated during this cleaning operation shall be discharged, vacuumed, or otherwise removed from the pipe.

6.17.3 Preparation

The test shall be applied at an approved outlet. The Contractor shall provide and later securely plug such fittings. The line shall be flushed, filled, and maintained at operating pressure for a period of at least 72 hours prior to testing to satisfy any system water absorption. (Seventy-two hour soak period not required for PVC pipe). While filling and immediately prior to testing, all air shall be expelled from the pipeline.

In selected cases, the fire department may require a check of the fire flow or pressure following construction. In such instances, the Owner/Contractor shall assist the fire department, as appropriate.

6.17.4 Procedure

After the 72-hour soak period, the pressure in the pipeline shall be increased to the specified test pressure. When the test pressure is reached, the pumping shall be discontinued until the pressure in the line has dropped 10 psi, at which time the pressure shall again be increased to the specified test pressure. This procedure shall be repeated until four hours have elapsed from the time the specified test pressure was first applied. At the end of this period, the pressure shall be increased to the test pressure for the last time.

6.17.5 Leakage

Leakage shall be considered as the total amount of water pumped into the pipeline during the four-hour period, including the amount required to reach the test pressure for the final time.

If leakage exceeds the allowable leakage, the leak points shall be located and stopped, and all defective pipe, fittings, valves, and other accessories discovered shall be removed and replaced.

Allowable leakage shall be computed as:

$$\text{Where: } L = \frac{CNDP}{1,850}$$

- L = Maximum allowable leakage in gallons per hour for the section of pipeline being treated
- C = 0.25 for PVC pipe with rubber gasket joints
- C = 0.50 for cast iron pipe with rubber gasket joints
- C = 0.125 for flanged joints
- C = 0 for welded steel pipe with welded joints
- N = Number of joints in length tested
- D = Diameter of pipe in inches
- P = Test pressure in psi

When the pipeline being tested contains more than one type of joint or pipe type allowable, leakage shall be computed for each, then summed for a total allowable leakage. The District Representative will provide the Contractor a temporary water meter to measure leakage.

6.18 DISINFECTION, SAMPLING, AND ANALYSIS

Disinfection is the last step necessary before connection to the existing water mains. After flushing and pressure testing, and prior to acceptance of the work, the entire pipeline including all valves, fittings, hydrants, service laterals, and other accessories shall be disinfected in accordance with the current AWWA Specification C651.

Contractor shall also comply with the requirements of:

- California State Water Resources Control Board (SWRCB) California Regulations Related to Drinking Water, Chapter 16. California Water Works Standards
- Order WQ 2014-0194-DWQ General Order No. CAG140001 Statewide National Pollutant Discharge Elimination System (NPDES) Permit for Drinking Water System Discharges to Waters of the United States

Contractor shall comply with Total Maximum Daily Loads (TMDLs) when performing work including:

Casitas Water System

- Total coliform (Ventura coastal)
- Algae (Ventura River)

Ojai Water System

- Algae (Ventura River)

TMDL requirements for both systems include tributaries to the Ventura River.

6.18.1 Repetition of Procedure

If the disinfection fails, then the procedure shall be repeated at the Contractor's expense until passing.

7 STANDARD DETAILS

SD-101	Pipe and Trench Backfill
SD-102	Thrust Blocks
SD-103	Mainline Valve and Anchor
SD-104	Turnout
SD-105	2-inch Air Valve
SD-106	2-inch Blow-off and End Drain
SD-107	4-inch Blow-off
SD-108	4-, 6-, and 8-inch Blow-off and End Drain
SD-109	Fire Hydrant Wet Barrel Type
SD-110	3-inch-12 inch Fire Service Double Detector Check Valve Assembly
SD-111	Meter Service Plan and Profile
SD-112	Meter Service Copper Pipe Material List
SD-113	Guard Post
SD-114	Water Sampling Station
SD-115	Marker Ball Detail

12" OVER CUT EACH SIDE OF TRENCH

1.5" MIN THICKNESS OVERLAP

UNPAVED CONDITION
PAVED CONDITION

EXISTING SURFACE

EXISTING PAVEMENT

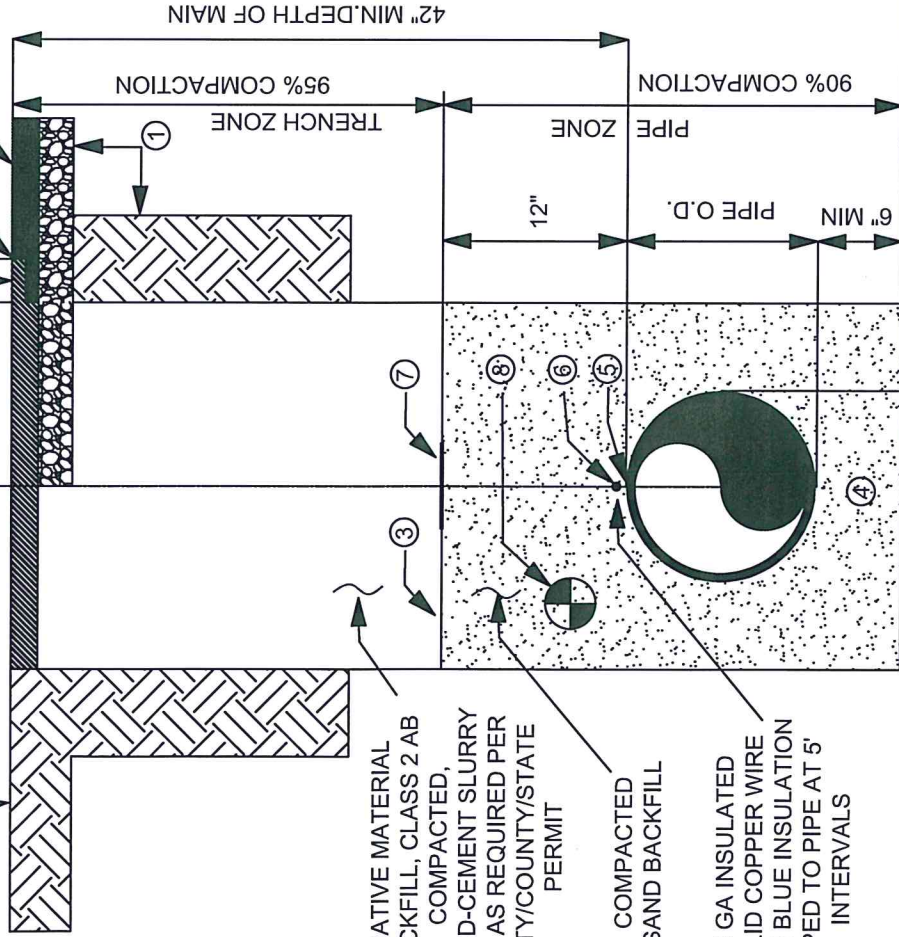

NATIVE MATERIAL BACKFILL, CLASS 2 AB COMPACTED, SAND-CEMENT SLURRY OR AS REQUIRED PER CITY/COUNTY/STATE PERMIT

COMPACTED SAND BACKFILL

12 GA INSULATED SOLID COPPER WIRE WITH BLUE INSULATION TAPED TO PIPE AT 5' INTERVALS

6" MIN-12" MAX ON EACH SIDE OF THE PIPE BELL

42" MIN. DEPTH OF MAIN

95% COMPACTION

90% COMPACTION

PIPE ZONE

12"

PIPE O.D.

6" MIN

NOTES:

- ① TRENCH, PAVEMENT AND SUBGRADE PER STATE, COUNTY, OR CITY STANDARDS OR PERMIT REQUIREMENTS
- ② CONTRACTOR SHALL HAND EXCAVATE "BELL HOLE" FOR EACH PIPE JOINT SO THAT THE WEIGHT OF THE PIPE DOES NOT REST ON THE BELL. CONTRACTOR SHALL REFILL AND HAND-TAMP EACH "BELL HOLE" PRIOR TO COMPLETING THE PLACEMENT OF THE BEDDING
- ③ IN AREAS WHERE NATIVE SOIL IS USED, THE COMPACTION IN THE TRENCH ZONE SHALL BE 95% AND IN THE PIPE ZONE 90%
- ④ PIPE BASE SHALL BE 12" THICK WHERE NATIVE MATERIAL HAS ROCKS LARGER THAN 6" IN TRENCH BOTTOM
- ⑤ PIPE SHALL BE ORIENTED WITH PRODUCT LABEL ON TOP
- ⑥ TRACER WIRE SHALL BE TAPED EVERY 5 FEET AND TESTED FOR ELECTRICAL CONTINUITY BY THE CONTRACTOR IN THE PRESENCE OF A DISTRICT REPRESENTATIVE PRIOR TO ACCEPTANCE OF THE PROJECT
- ⑦ WARNING MARKER TAPE
- ⑧ PLACE MARKER BALL IN SAND BACKFILL ABOVE PIPE PER SD - 115

PIPE AND TRENCH BACKFILL

APPROVED *Shawna* 3/3/21
ENGINEERING MANAGER DATE:

APPROVED *Michael Shields* 3-4-21
OPERATIONS AND MAINTENANCE MANAGER DATE:

APPROVED *Michael Shields* 3/3/21
GENERAL MANAGER DATE:



CASE A

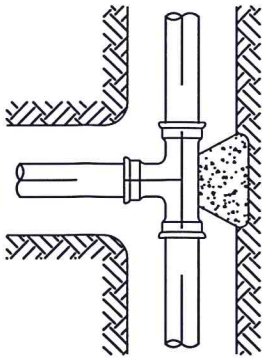

CASE B

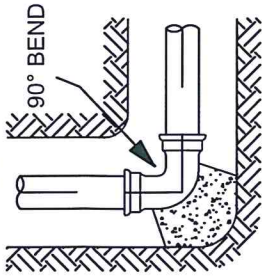

CASE C

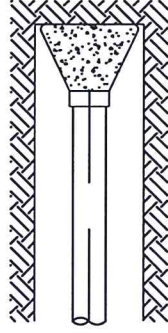

CASE D

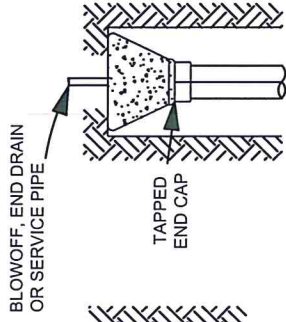

CASE E

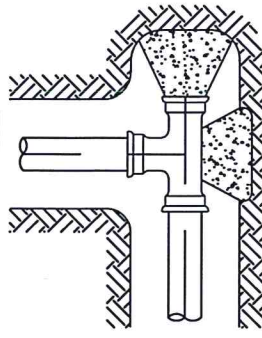

CASE F

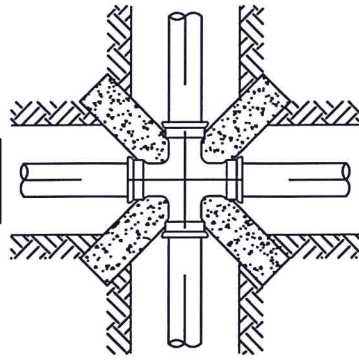

CASE G

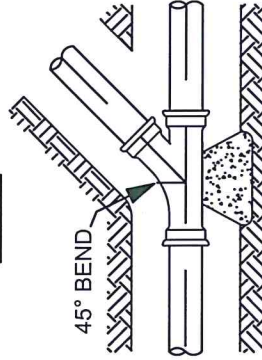

CASE H

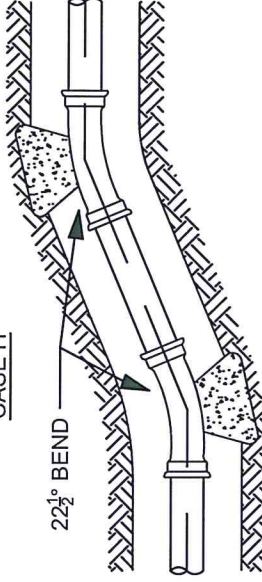

CASE I

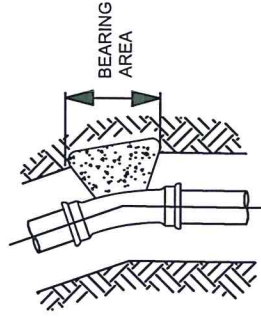
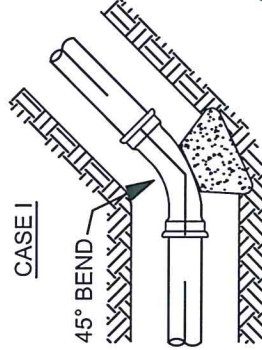

PLAN



SECTION

TYPICAL CROSS-SECTION

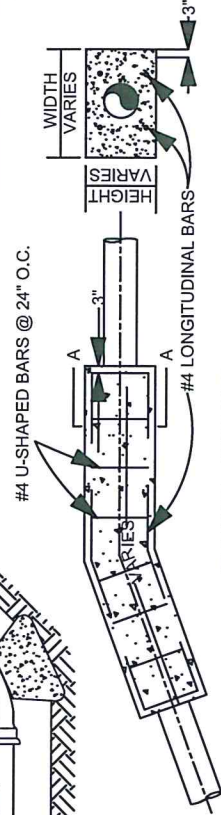

TYPICAL ANCHOR

ENCASEMENT

NOTES:

- ① THRUST BLOCK AREAS BASED ON 225 PSI PRESSURE AND 2,000 PSF ALLOWABLE SOIL PRESSURE WITH 2 1/2 FEET OF COVER MINIMUM. ADDITIONAL BEARING AREA REQUIRED FOR SPECIAL CONDITIONS SHALL BE APPROVED THE DISTRICT ENGINEER
- ② THRUST BLOCK BEARING FACES SHALL BE PLACED AGAINST UNDISTURBED SOIL OR DISTRICT APPROVED COMPACTED BACKFILL

THRUST BLOCK BEARING AREA IN SQUARE FEET

PIPE SIZE	DESCRIPTION (CASE)										
	A	B	C	D	E	F	G	H	I	30°	60°
4"	6	6	6	6	2@3.1	4@1.2	3	4@1.2	3	4	4
6"	6	6	6	6	2@6.3	4@2.5	5	4@2.5	5	4	6
8"	12	16	12	12	2@11	4@4.2	9	4@4.2	9	6	16
10"	18	29	18	18	2@17	4@6.4	13	4@6.4	13	13	29
12"	24	37	24	24	2@24	4@9.0	18	4@9.0	18	18	37
14"	31	44	31	31	2@31	4@13	24	4@13	24	24	44
16"	41	57	41	41	2@40	4@16	31	4@16	31	31	57

THRUST BLOCKS

APPROVED *Maquandel 3/3/21* DATE: 3/3/21
 ENGINEERING MANAGER

APPROVED *Michael Shields 3-4-21* DATE: 3-4-21
 OPERATIONS AND MAINTENANCE MANAGER

APPROVED *Michael Shields 3/8/21* DATE: 3/8/21
 GENERAL MANAGER



REV. DATE: FEB 2021

SD-102

CHRISTY G3 VALVE BOX WITH COVER MARKED "CMWD WATER"

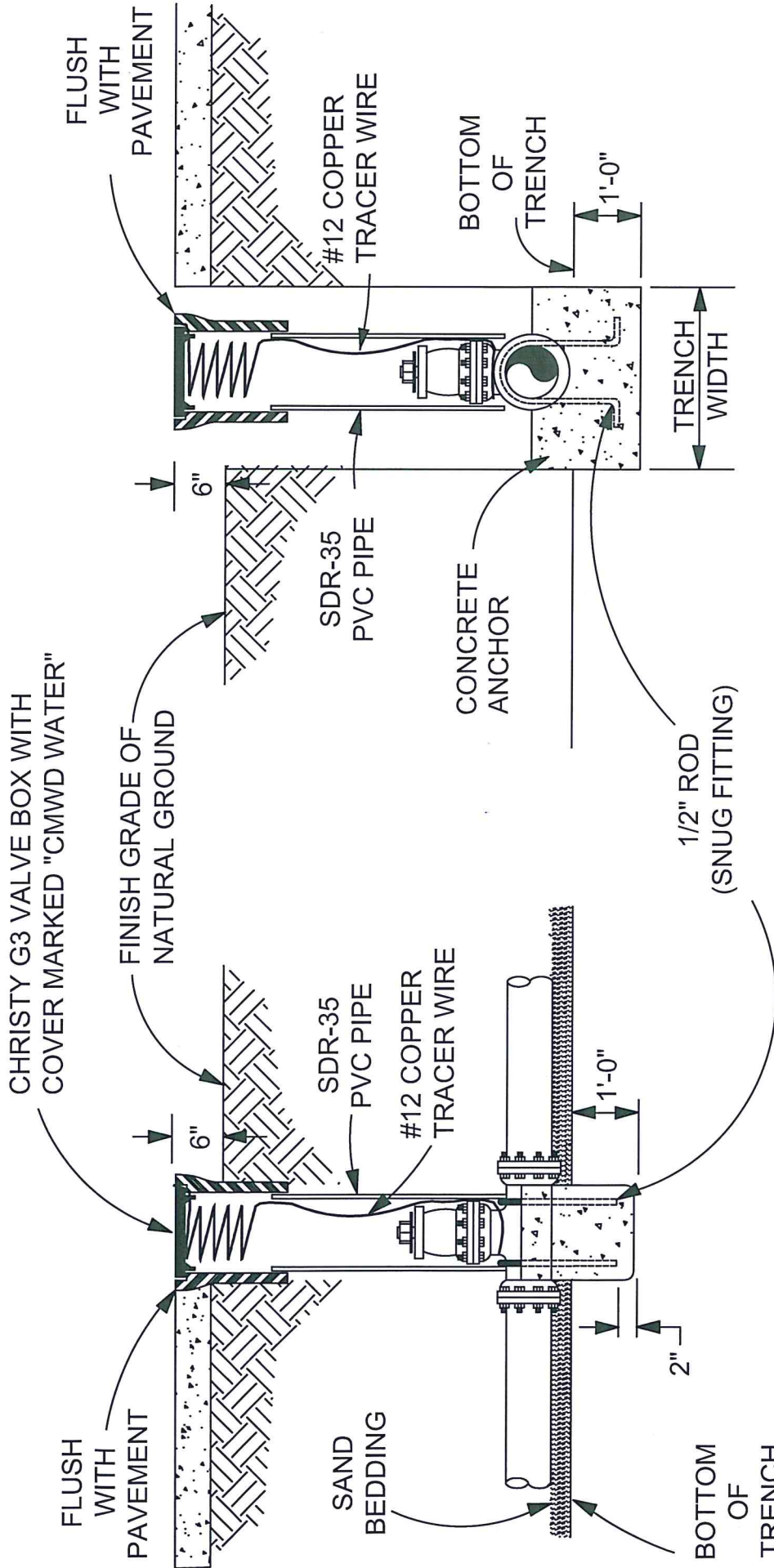

SIDE VIEW

END VIEW

APPROVED <i>Michael Shields</i> ENGINEERING MANAGER	DATE: 3/3/21		MAINLINE VALVE AND ANCHOR
APPROVED <i>Michael Shields</i> OPERATIONS AND MAINTENANCE MANAGER	DATE: 3-4-21		
APPROVED <i>Michael Shields</i> GENERAL MANAGER	DATE: 3/8/21		
		REV. DATE:	FEB 2021
			SD-103

CHRISTY G3 VALVE BOX WITH
COVER MARKED "CMWD WATER"

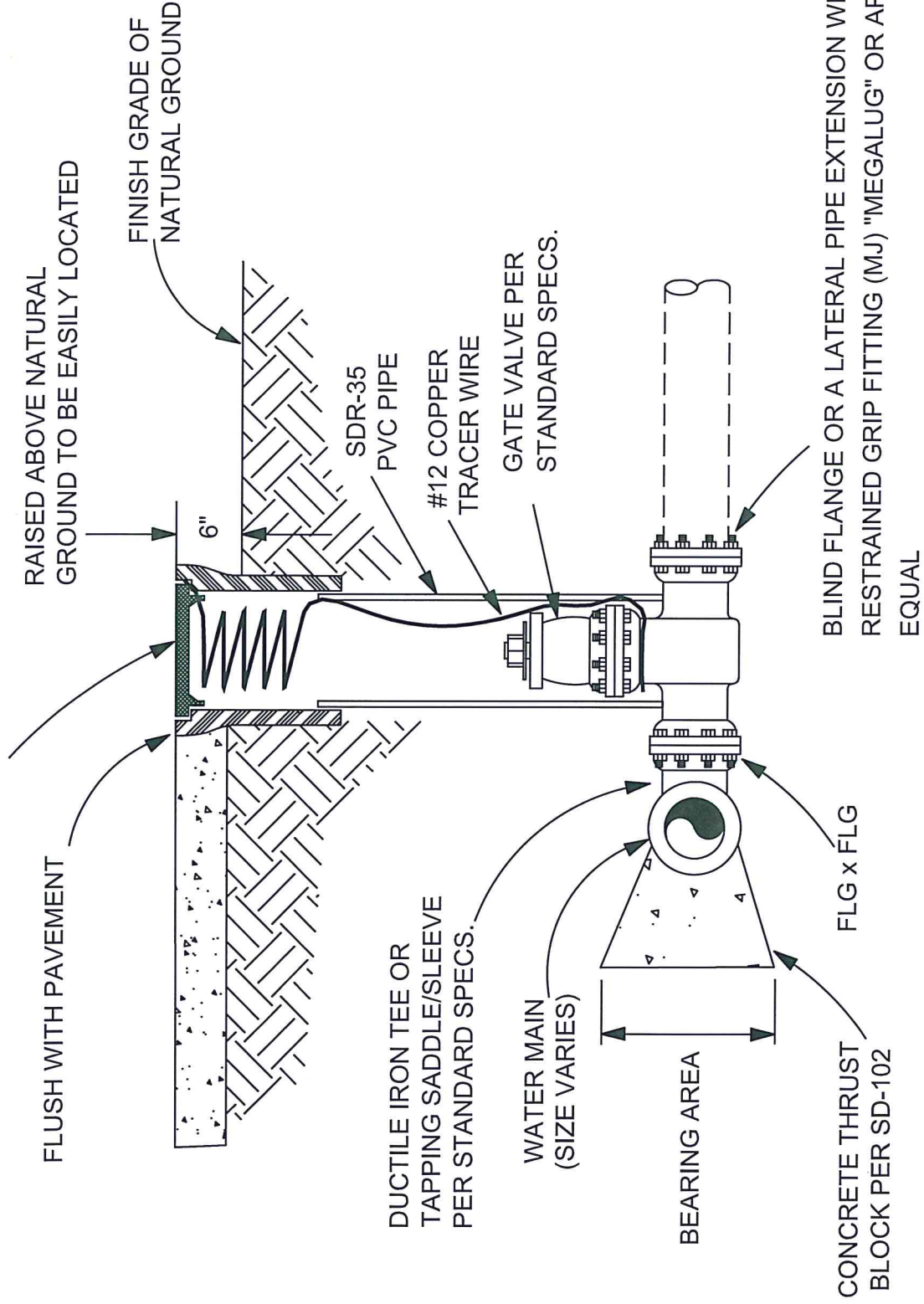

APPROVED	<i>[Signature]</i>	ENGINEERING MANAGER	DATE: 3/3/21
APPROVED	<i>[Signature]</i>	OPERATIONS AND MAINTENANCE MANAGER	DATE: 3-4-21
APPROVED	<i>[Signature]</i>	GENERAL MANAGER	DATE: 3/3/21

TURNOUT



REV. DATE: FEB 2021

SD-104

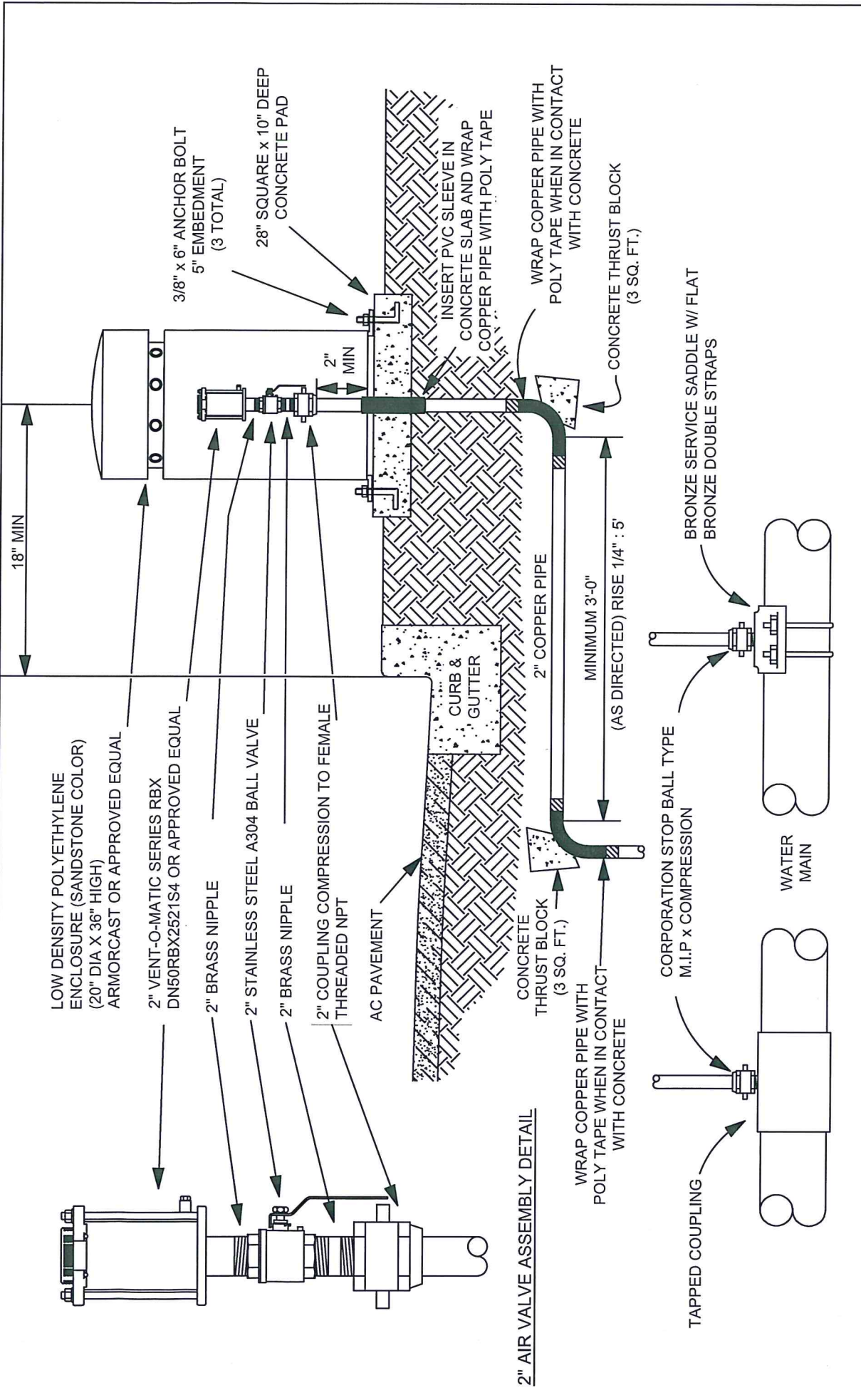

2" AIR VALVE ASSEMBLY DETAIL

NOTES:

- ① FOR CONNECTION TO STEEL PIPE, USE APPROVED SERVICE SADDLE OR REINFORCED WELDED HEAVY COUPLING
- ② TWO GUARD POSTS REQUIRED PER SD-113
- ③ GUARD POSTS SHALL BE PLACED WHEN ALLOWABLE IN A LOCATION SATISFACTORY TO THE ENGINEER AND AGENCY HAVING JURISDICTION

APPROVED <i>Michael Shields</i> ENGINEERING MANAGER DATE: 3/3/21	
APPROVED <i>Michael Shields</i> OPERATIONS AND MAINTENANCE MANAGER DATE: 3-4-21	
APPROVED <i>Michael Shields</i> GENERAL MANAGER DATE: 3/8/21	

2" AIR VALVE

DISTANCE AS DIRECTED BY PLANS OR THE ENGINEER

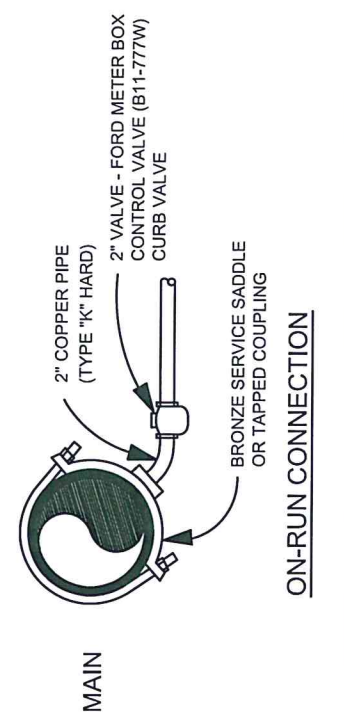
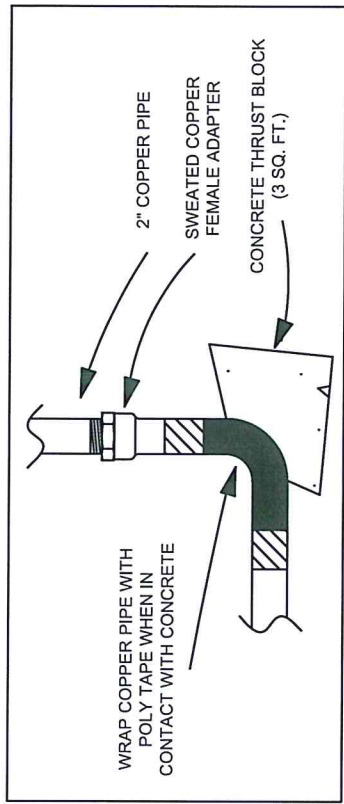
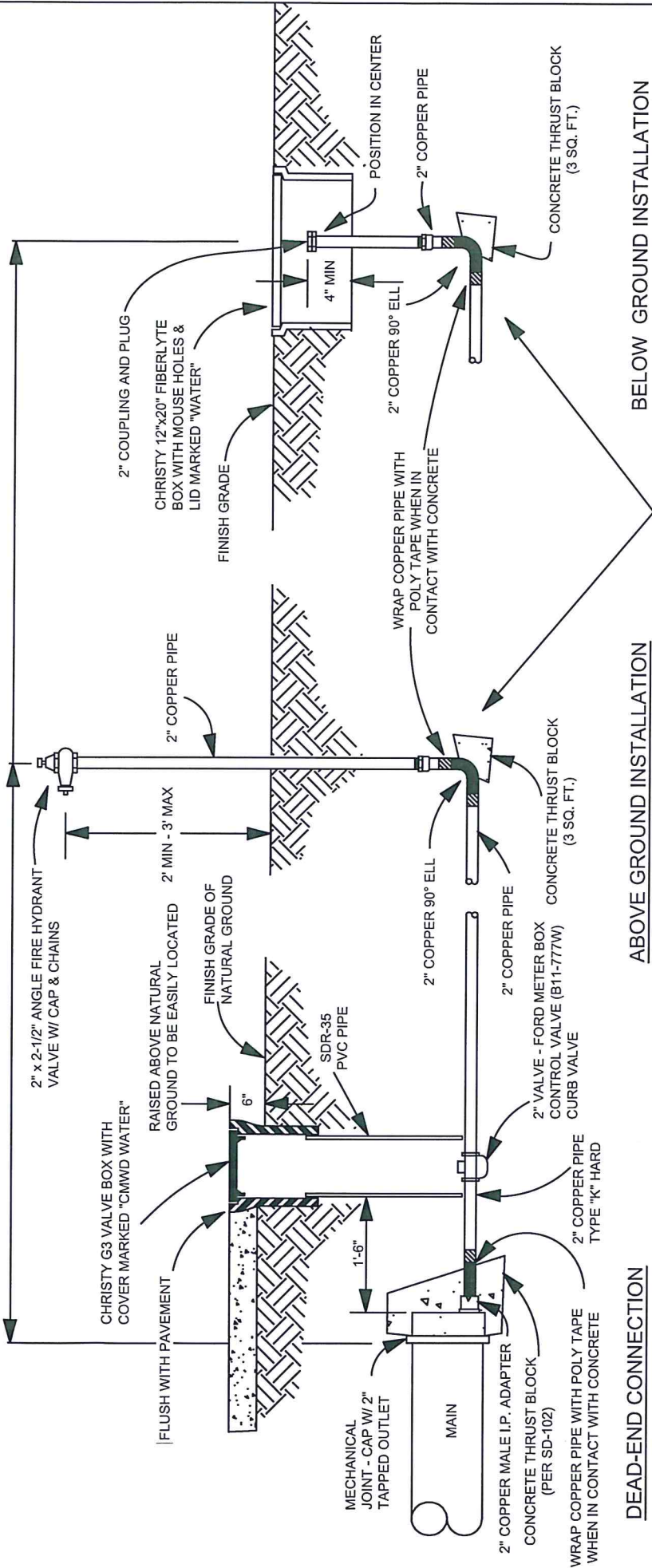

NOTES:

- ① FOR CONNECTION TO STEEL PIPE, USE APPROVED SERVICE SADDLE OR REINFORCED WELDED HEAVY COUPLING
- ② TWO GUARD POSTS REQUIRED FOR ABOVE GROUND INSTALLATION PER SD-113
- ③ GUARD POSTS SHALL BE PLACED WHEN ALLOWABLE IN A LOCATION SATISFACTORY TO THE ENGINEER AND AGENCY HAVING JURISDICTION

APPROVED <i>Michael Shields</i> ENGINEERING MANAGER	DATE: 3/3/21
APPROVED <i>Michael Shields</i> OPERATIONS AND MAINTENANCE MANAGER	DATE: 3-4-21
APPROVED <i>Michael Shields</i> GENERAL MANAGER	DATE: 3/8/21

2" BLOW OFF & END DRAIN



REV. DATE: FEB 2021

SD-106

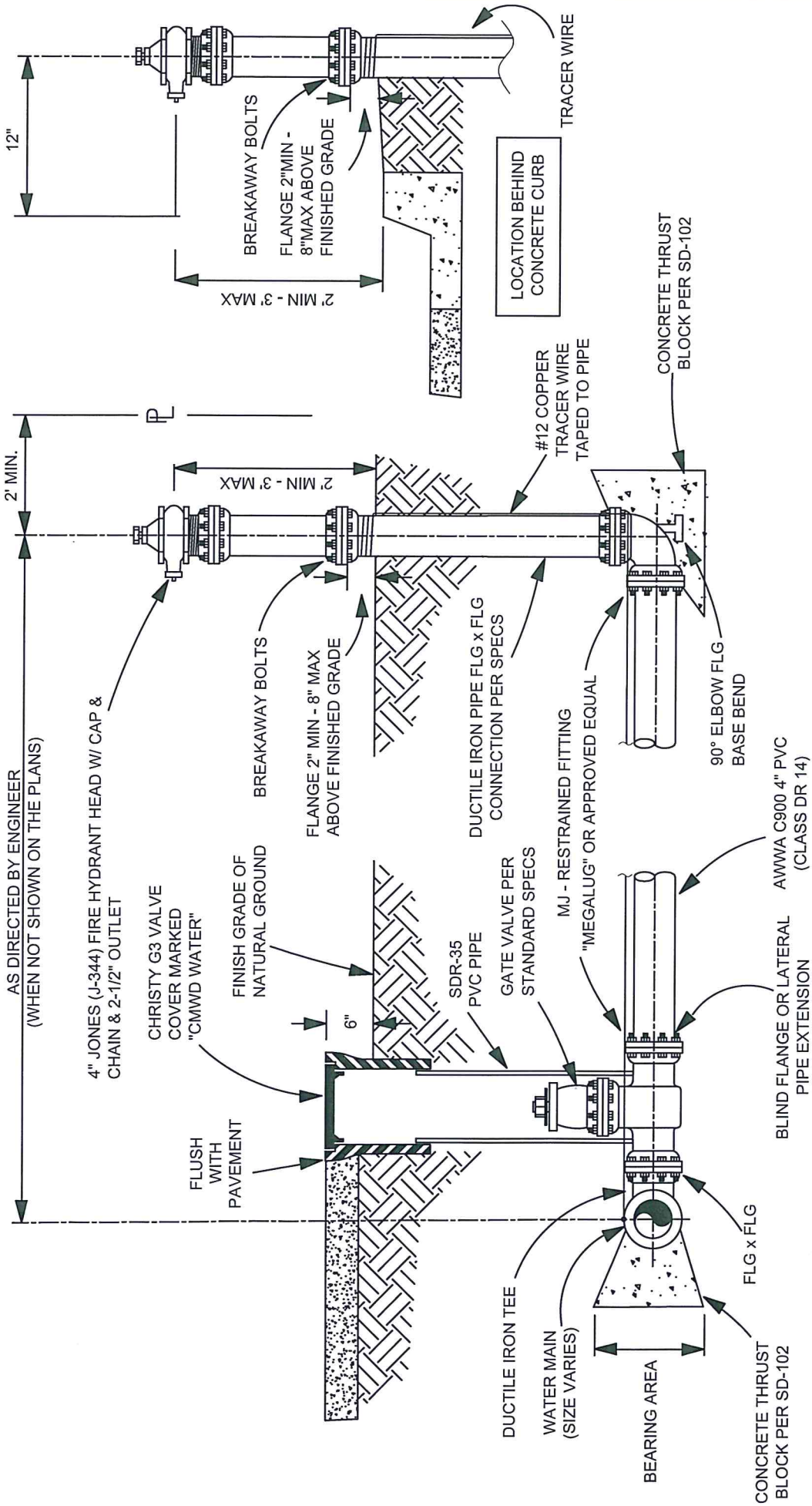

NOTES:

- ① A MINIMUM OF TWO GUARD POSTS ARE REQUIRED FOR EACH ABOVEGROUND 4" BLOW-OFF PER SD-113
- ② ALL METAL MATERIAL, WITH THE EXCEPTION OF THE VALVE BOX, SHALL BE WRAPPED WITH TWO LAYERS OF 8 MIL. POLYETHYLENE SECURELY TAPED IN PLACE

APPROVED *Guillermo 3/3/21* ENGINEERING MANAGER DATE:

APPROVED *Michael Shields 3-4-21* OPERATIONS AND MAINTENANCE MANAGER DATE:

APPROVED *Michael Hood 3/8/21* GENERAL MANAGER DATE:

4" BLOW OFF

ASITAS
Municipal Water District

REV. DATE: FEB 2021

SD-107

AS DIRECTED
(WHEN NOT SHOWN ON THE PLANS)

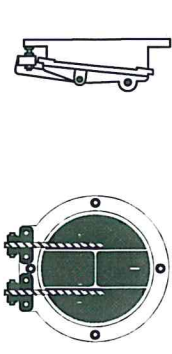

PLAN
WATERMAN F-25 MEDIUM DUTY FLAP GATE OR APPROVED EQUAL

PROFILE
WATERMAN F-25 MEDIUM DUTY FLAP GATE OR APPROVED EQUAL

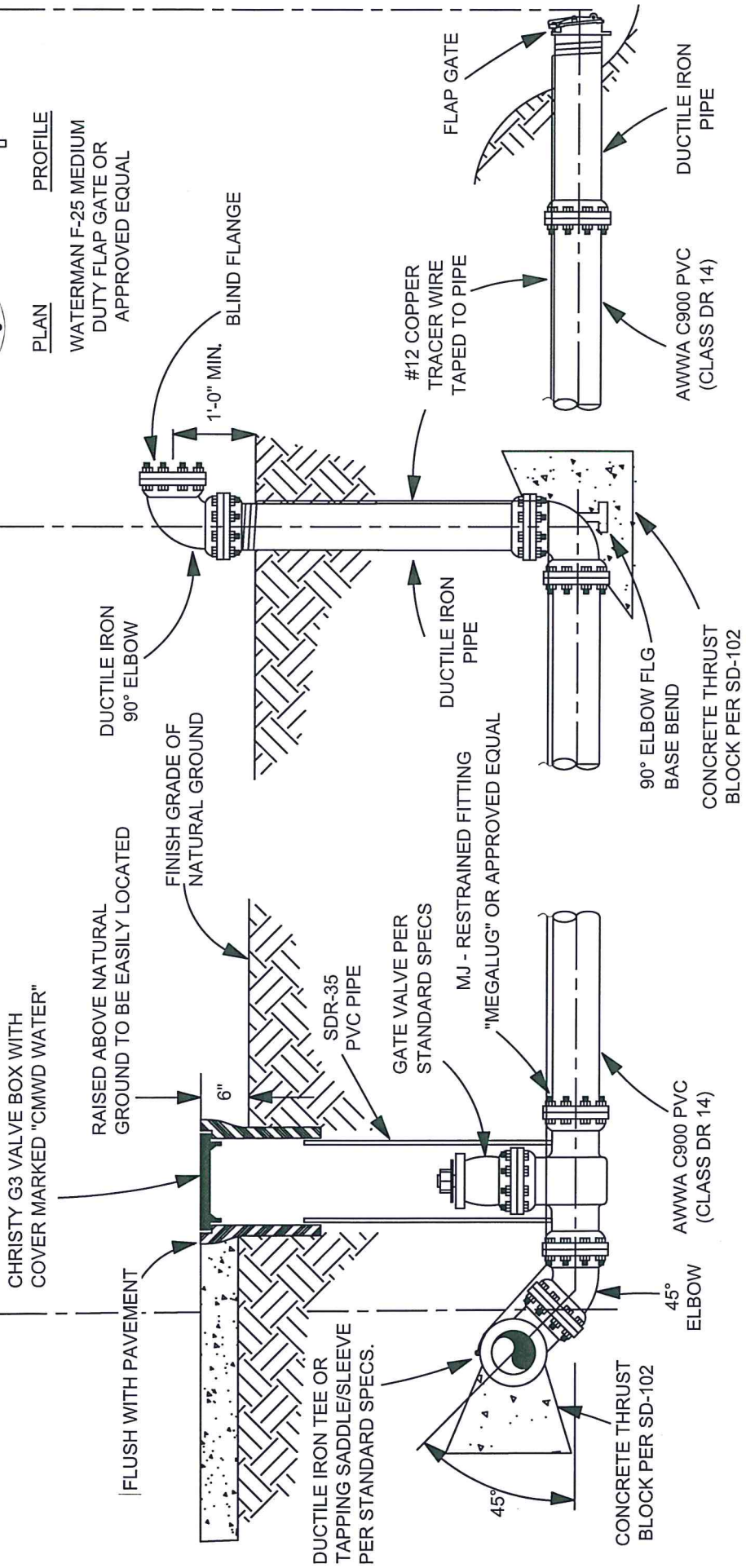

BLOW - OFF

TYPE "A" (DUCTILE IRON PIPE)

TYPE "B" (DUCTILE IRON PIPE)

NOTES:

- 1 TYPE "A" OR "B" - EITHER AS SHOWN ON THE PLANS OR AS DIRECTED BY ENGINEER
- 2 TWO GUARD POSTS REQUIRED FOR ABOVE GROUND INSTALLATION PER SD-113
- 3 GUARD POSTS SHALL BE PLACED WHEN ALLOWABLE IN A LOCATION SATISFACTORY TO THE ENGINEER AND AGENCY HAVING JURISDICTION

APPROVED: *Michael Shields* 3/3/21
ENGINEERING MANAGER DATE:

APPROVED: *Michael Shields* 3-4-21
OPERATIONS AND MAINTENANCE MANAGER DATE:

APPROVED: *Michael Shields* 3/8/21
GENERAL MANAGER DATE:

**4"-6"-8"
BLOW-OFF AND END DRAIN**



REV. DATE: FEB 2021

SD-108

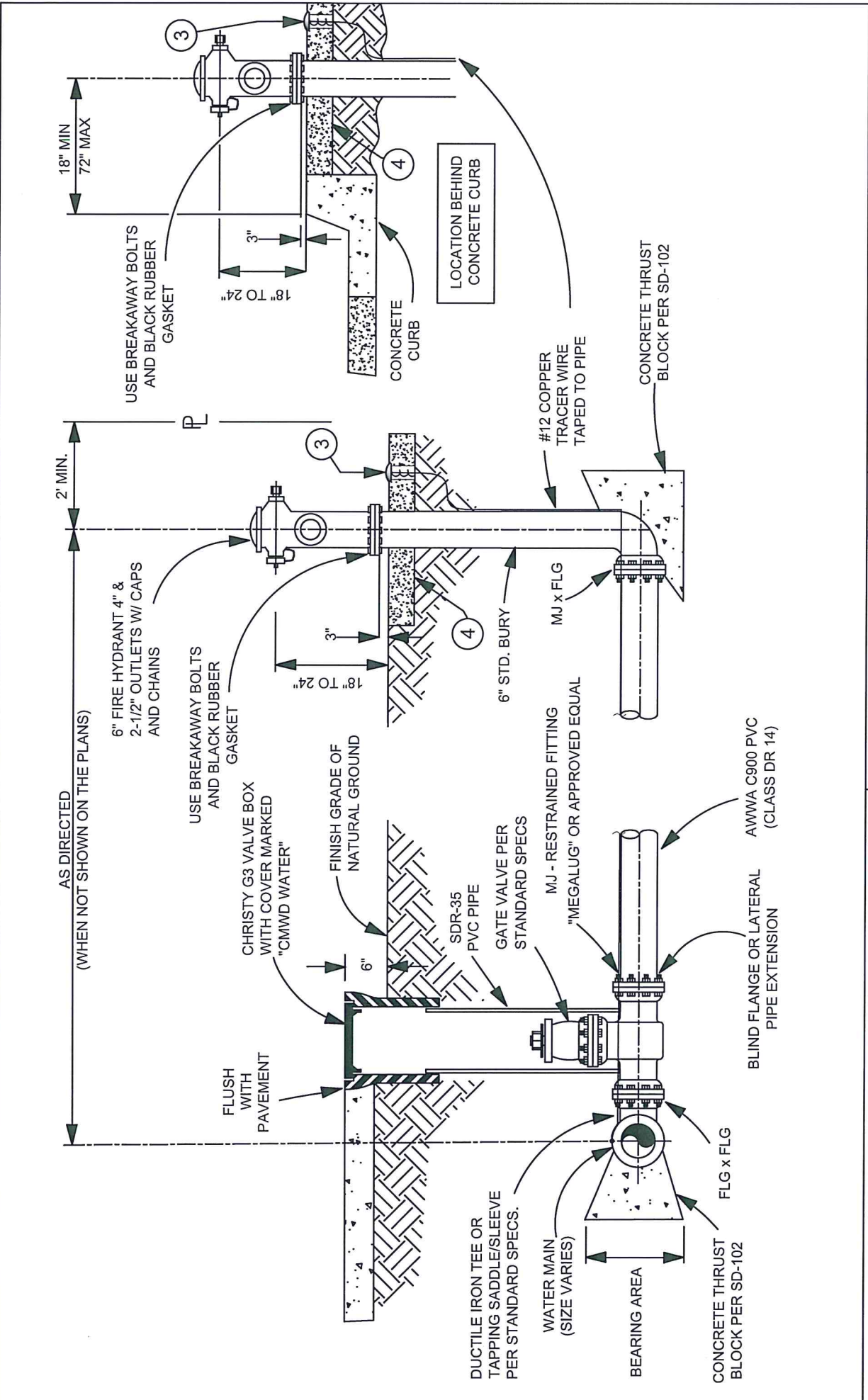

FIRE HYDRANT WET BARREL	
APPROVED <i>Michael Shields</i> 3/3/21 ENGINEERING MANAGER DATE	REV. DATE: FEB 2021
APPROVED <i>Michael Shields</i> 3-4-21 OPERATIONS AND MAINTENANCE MANAGER DATE	SD-109
APPROVED <i>Michael Shields</i> 3/8/21 GENERAL MANAGER DATE	
<p>NOTES:</p> <p>① A MINIMUM OF TWO GUARD POSTS ARE REQUIRED FOR EACH FIRE HYDRANT PER SD-113, UNLESS ENCROACHMENT PERMIT STATES OTHERWISE</p> <p>② ALL METAL MATERIAL, WITH THE EXCEPTION OF THE VALVE BOX, SHALL BE WRAPPED WITH TWO LAYERS OF 8 MIL. POLYETHYLENE SECURELY TAPED IN PLACE</p> <p>③ TRACER WIRE JUNCTION BOX SHALL BE A SNAKEPIT CD14TP - BLUE MANUFACTURED BY COPPERHEAD INDUSTRIES LLC., OR APPROVED EQUAL</p> <p>④ CONCRETE PAD - 36" SQUARE BY 12" DEEP</p>	



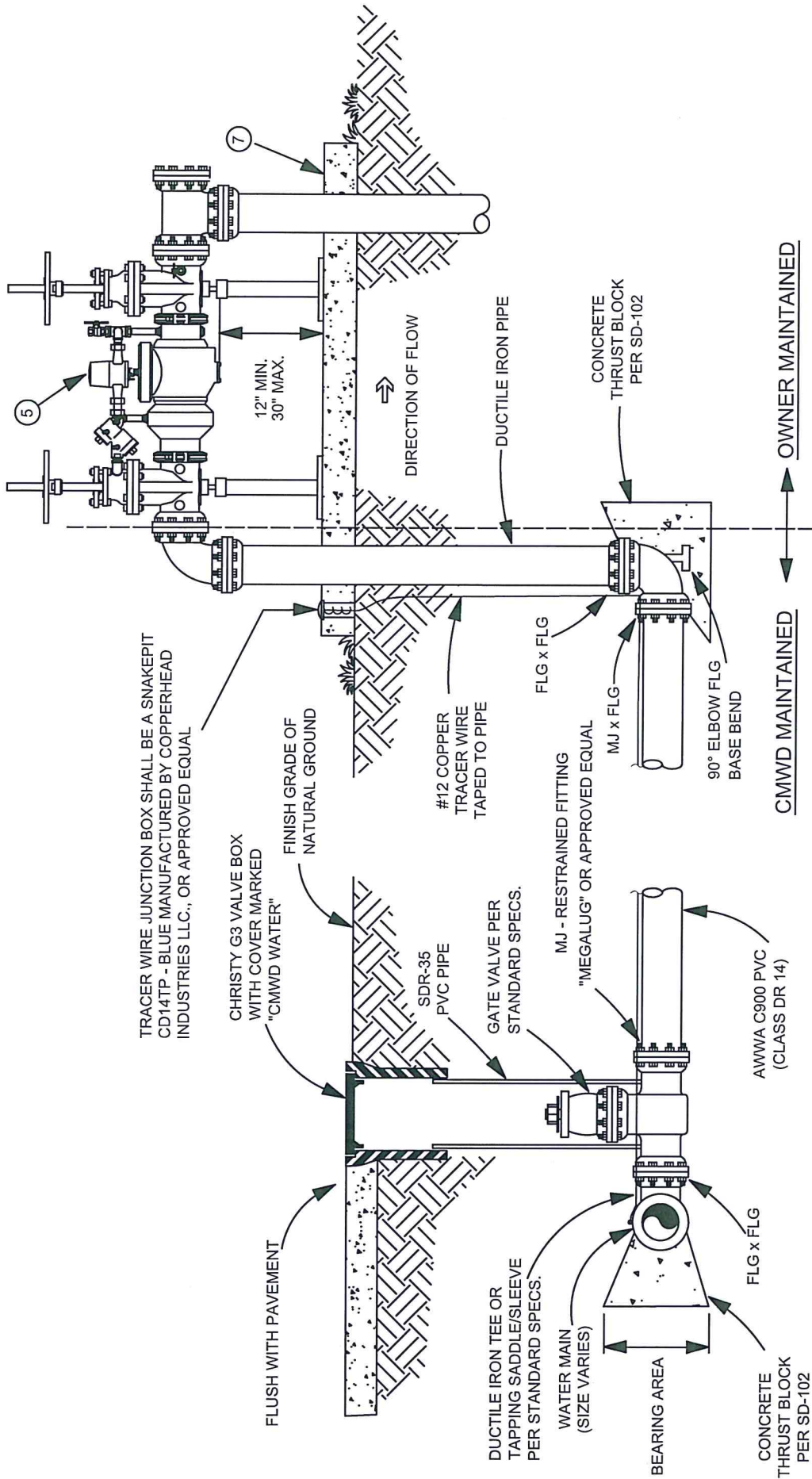

- NOTES:
- ① DOUBLE CHECK DETECTOR REQUIRED ON ALL POTABLE DEDICATED FIRELINES
 - ② DEVICE MUST BE ON THE APPROVED USC LIST AND ACCEPTABLE TO CMWD
 - ③ DEVICE SHOULD BE INSTALLED AS CLOSE TO PROPERTY LINE AS POSSIBLE
 - ④ MAINTAIN A 24" CLEARANCE BETWEEN DEVICE AND ANY OBSTRUCTIONS
 - ⑤ CMWD-INSTALLED BYPASS METER PURCHASED BY CUSTOMER
 - ⑥ PLACE BACKFLOW DEVICE AS CLOSE AS POSSIBLE TO METER
 - ⑦ PAD DIMENSIONS TO BE DETERMINED BY CMWD BASED ON METER SIZE AND SITE CONDITIONS

APPROVED *Marcus* 3/3/21
 ENGINEERING MANAGER DATE:

APPROVED *Mikal Shields* 3-4-21
 OPERATIONS AND MAINTENANCE MANAGER DATE:

APPROVED *Michelle* 3/8/21
 GENERAL MANAGER DATE:

3"-12" FIRE SERVICE DOUBLE DETECTOR CHECK VALVE ASSEMBLY

REV. DATE: FEB 2021

SD-110

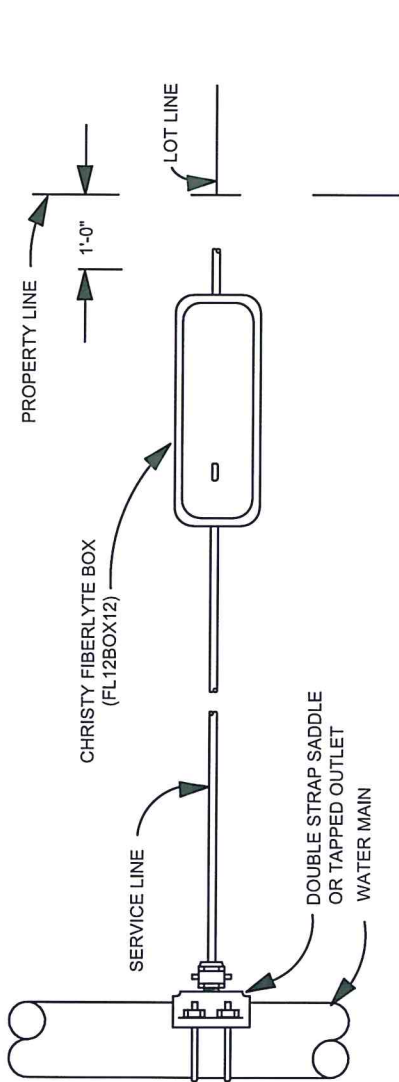

PLAN

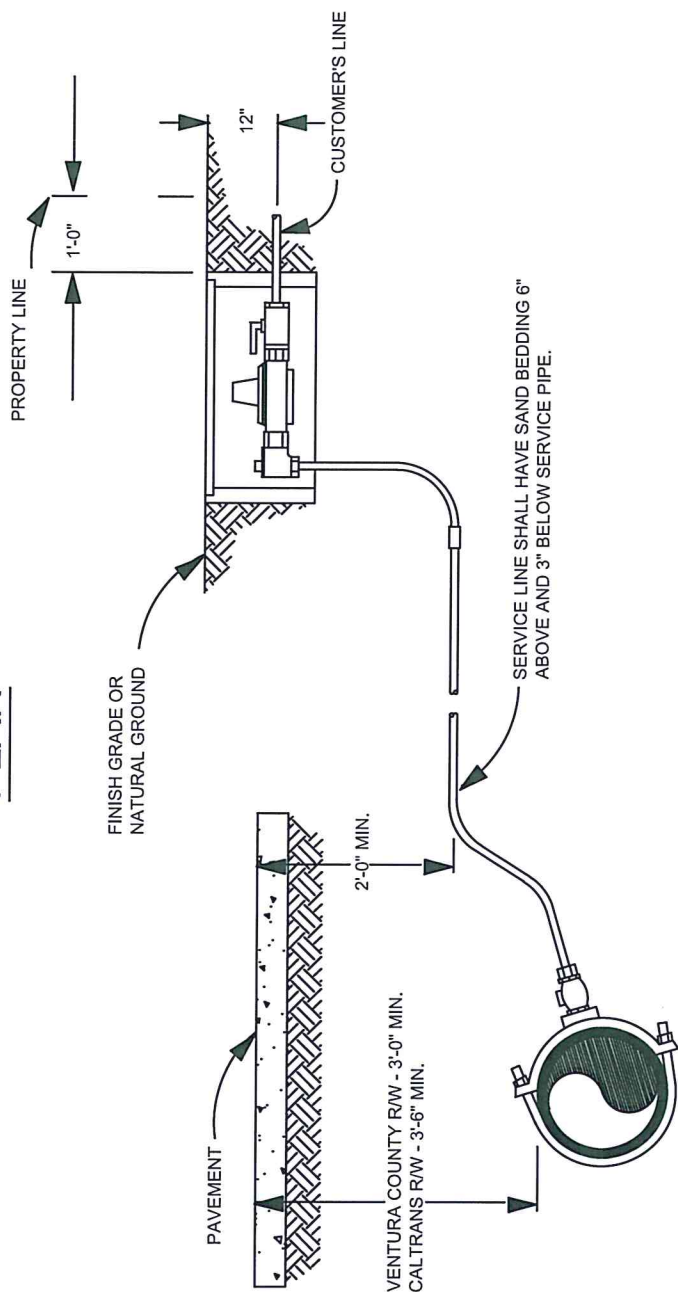

PROFILE

MAIN

NOTES:

- ① CURBS, AS REFERRED TO ON THESE DRAWINGS, MEAN CONCRETE CURBS AND GUTTERS
- ② FOR INSTALLATIONS WHERE SIDEWALK ABUTS CURB AND THE PROPERTY LINE, METER BOXES ARE SET FLUSH IN THE SIDEWALK AND ADJACENT TO THE BACK OF THE CURB. INSTALL 2" PVC SLEEVE UNDER SIDEWALK
- ③ FOR INSTALLATIONS IN AREA WITH PARKWAY BETWEEN CONC. CURB AND SIDEWALK, METER BOXES ARE SET FLUSH WITH TOP OF CURB AND ADJACENT TO BACK OF CURB
- ④ FOR MATERIAL LIST SEE DETAILS ON SD-112

APPROVED *Shuanan* 3/3/21
ENGINEERING MANAGER DATE:

APPROVED *Michael Shields* 3-4-21
OPERATIONS AND MAINTENANCE MANAGER DATE:

APPROVED *Atal* 3/3/21
GENERAL MANAGER DATE:

METER SERVICE PLAN & PROFILE



REV. DATE: FEB 2021

SD-111

MATERIAL LIST FOR TYPICAL WATER SERVICE					
ITEM NO.	DESCRIPTION OF ITEM	SIZE & TYPE OF SERVICE			MATERIAL DESCRIPTION
		3/4"	1"	2"	
1	SERVICE SADDLE (DOUBLE STRAP) I.P. THREADS	1	1	1	J-979, J-996, F202B, F202BS
2	CORPORATION STOP I.P. THREADS	1	1	1	J-3403SG, FB1100-4Q
3	COPPER TUBING	1	1	1	
4	ANGLE METER STOP	1	1	1	
5	CUSTOMER SIDE VALVE	1	1	1	
6	BRASS NIPPLE (2-1/2" LENGTH)	1	1	1	STANDARD WEIGHT
7	INSULATING COUPLING	1	1	1	RALEIGH MODEL 700
8	CUSTOMER SERVICE NIPPLE (12" LENGTH)	1	1	1	PVC PIPE, SCH. 80, T&T
9	METER BOX	1	1	1	

3/4"		1"		2"	
△	TYPE "K" SOFT	TYPE "K" SOFT	TYPE "K" SOFT	TYPE "K" SOFT	TYPE "K" SOFT
△	H-14259 OR J-4201SG	H-14259, J-4201SG, FORD BA43	JONES J-1975WSG, BFA43		
△	FORD B-13, JONES J-1908	FORD B-13, JONES J-1908	BF13-777, JONES J-1913W		
△	CHRISTY FIBERLYTE (FL12BOX12)	CHRISTY FIBERLYTE (FL12BOX12)	CHRISTY FIBERLYTE (FL36BOX12)		

NOTE: MAXIMUM PRESSURE = 150 P.S.I.

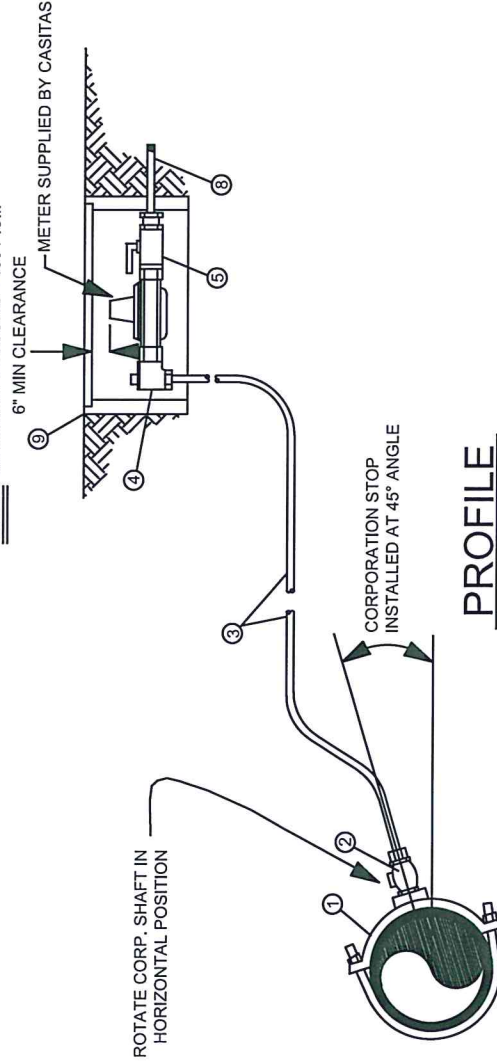

MAIN

PROFILE

NOTES:

- 1 REFER TO DISTRICT'S SPECIFICATIONS, APPURTENANT STRUCTURES, FOR MATERIAL SPECIFICATIONS
- 2 COPPER TUBING CONNECTIONS SHALL BE MUELLER 110 OR JAMES JONES SUPER GRIP
- 3 CONTRACTOR SHALL CONNECT TO CUSTOMER SIDE PLUMBING IN ACCORDANCE WITH NATIONAL STANDARD PLUMBING CODE

APPROVED *Michael Smith*
ENGINEERING MANAGER DATE: 3-4-21

APPROVED *Michael Smith*
OPERATIONS AND MAINTENANCE MANAGER DATE: 3-4-21

APPROVED *Michael Smith*
GENERAL MANAGER DATE: 3-4-21

METER SERVICE COPPER PIPE MATERIAL LIST



REV. DATE: FEB 2021

SD-112

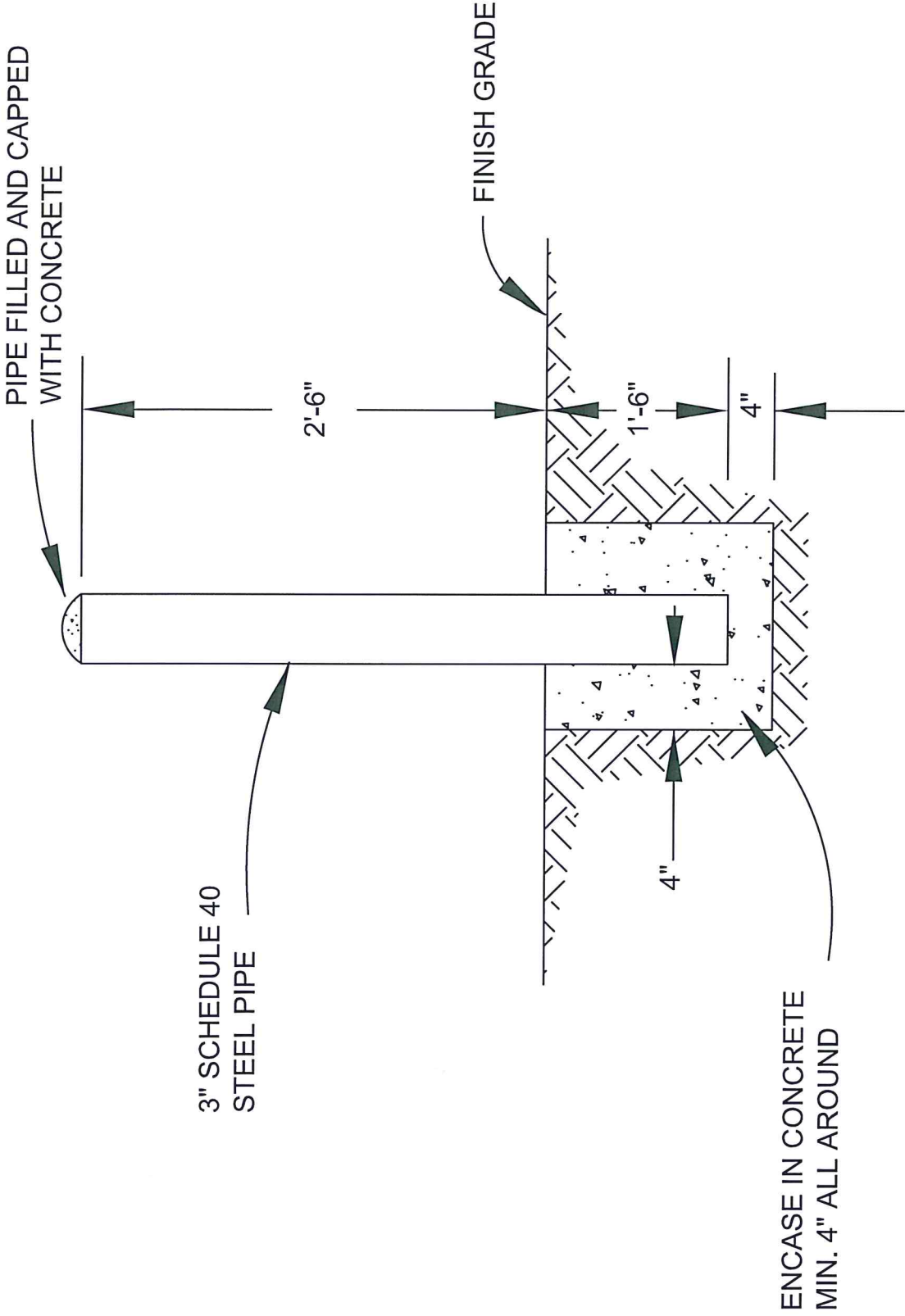

NOTES:

- ① GUARD POSTS SHALL BE PLACED WHEN ALLOWABLE IN A LOCATION SATISFACTORY TO THE ENGINEER AND AGENCY HAVING JURISDICTION
- ② GUARD POSTS SHALL BE PLACED SO AS NOT TO OBSTRUCT THE INTENDED USE OF THE APPURTENANCE
- ③ GUARD POSTS SHALL BE PAINTED PER SPECIFICATIONS

APPROVED *Shamuel* 3/3/21
ENGINEERING MANAGER DATE:

APPROVED *Michael Shickel* 3-4-21
OPERATIONS AND MAINTENANCE MANAGER DATE:

APPROVED *Michael Shickel* 3/3/21
GENERAL MANAGER DATE:

GUARD POST

REV. DATE: FEB 2021

SD-113

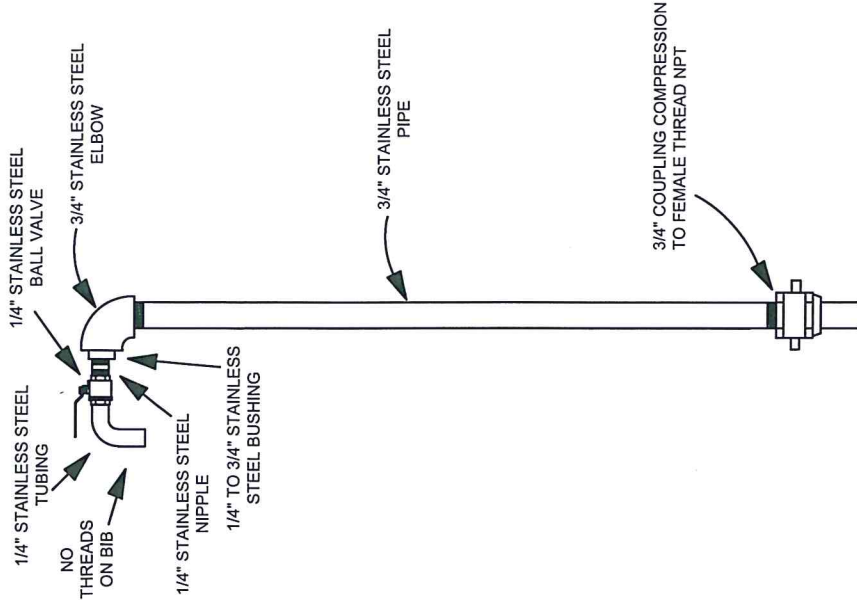

SAMPLE VALVE DETAIL

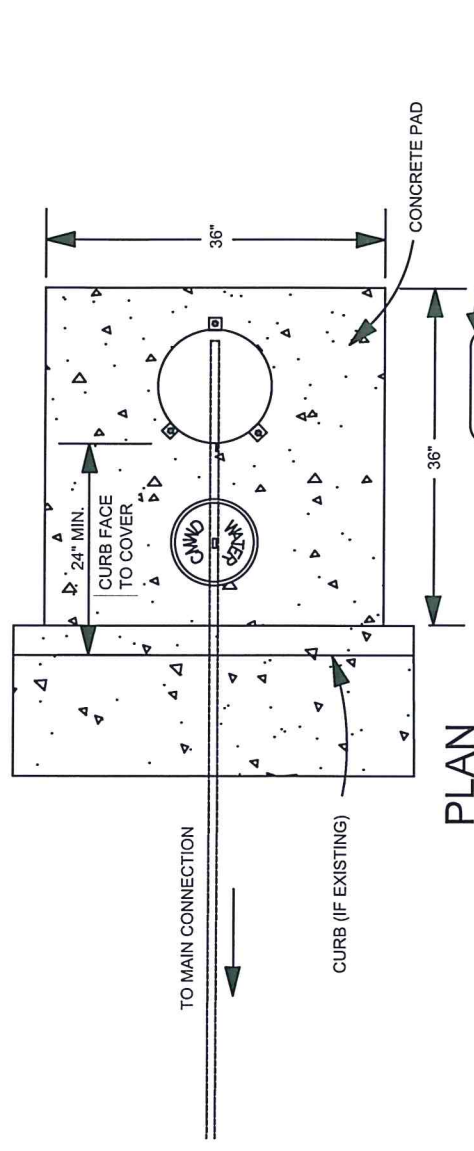

PLAN

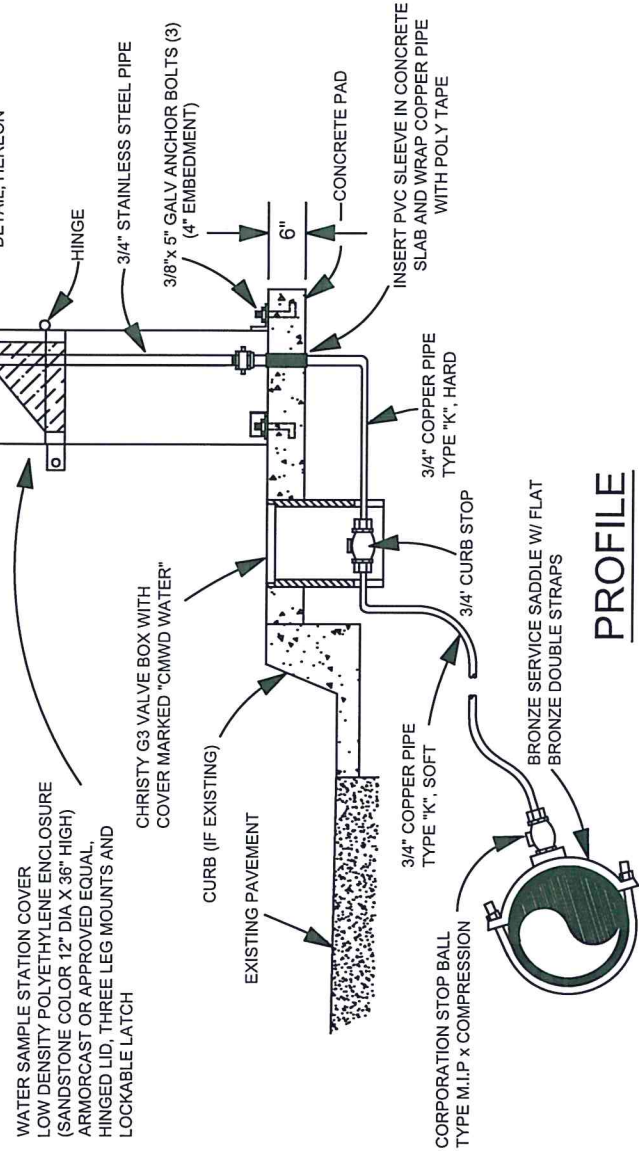

PROFILE

NOTES:

- ① STATION COVER MUST BE INSTALLED PLUMB
- ② WATER SAMPLE LINE TO BE INSTALLED FROM MAIN PER SD-111
- ③ STENCIL "CMWD" AND STATION NO. AS DIRECTED BY THE DISTRICT ENGINEER

APPROVED: <i>Michael Shields</i> 3/3/21	ENGINEERING MANAGER	DATE:
APPROVED: <i>Michael Shields</i> 3-4-21	OPERATIONS AND MAINTENANCE MANAGER	DATE:
APPROVED: <i>Michael Shields</i> 3/8/21	GENERAL MANAGER	DATE:

WATER SAMPLING STATION



REV. DATE: FEB 2021

SD-114

Approved/Revised/Deleted/Added/Cancelled/Deleted/Details

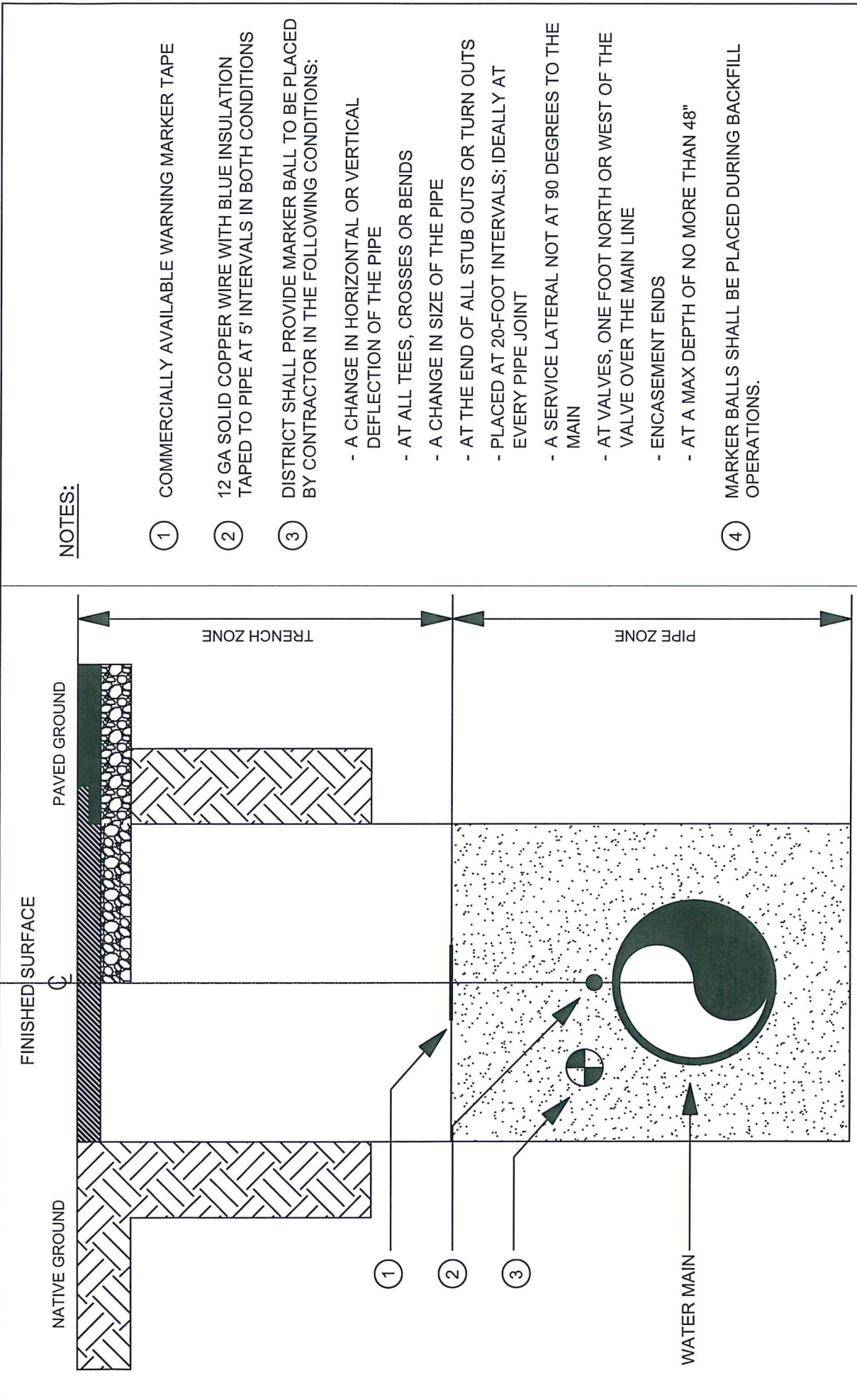

NOTES:

- ① COMMERCIALY AVAILABLE WARNING MARKER TAPE
- ② 12 GA SOLID COPPER WIRE WITH BLUE INSULATION TAPED TO PIPE AT 5' INTERVALS IN BOTH CONDITIONS
- ③ DISTRICT SHALL PROVIDE MARKER BALL TO BE PLACED BY CONTRACTOR IN THE FOLLOWING CONDITIONS:
 - A CHANGE IN HORIZONTAL OR VERTICAL DEFLECTION OF THE PIPE
 - AT ALL TEES, CROSSES OR BENDS
 - A CHANGE IN SIZE OF THE PIPE
 - AT THE END OF ALL STUB OUTS OR TURN OUTS
 - PLACED AT 20-FOOT INTERVALS; IDEALLY AT EVERY PIPE JOINT
 - A SERVICE LATERAL NOT AT 90 DEGREES TO THE MAIN
 - AT VALVES, ONE FOOT NORTH OR WEST OF THE VALVE OVER THE MAIN LINE
 - ENCASEMENT ENDS
 - AT A MAX DEPTH OF NO MORE THAN 48"
- ④ MARKER BALLS SHALL BE PLACED DURING BACKFILL OPERATIONS.

MARKER BALL DETAIL		ASITAS Municipal Water District	SD-115
APPROVED <i>[Signature]</i> <small>ENGINEERING MANAGER</small>	DATE: 3/3/21	APPROVED <i>[Signature]</i> <small>OPERATIONS AND MAINTENANCE MANAGER</small>	REV. DATE: FEB 2021
APPROVED <i>[Signature]</i> <small>GENERAL MANAGER</small>		DATE: 3/8/21	